

28TH CEDAR'S RALLY

July 20th & 21st, 2019

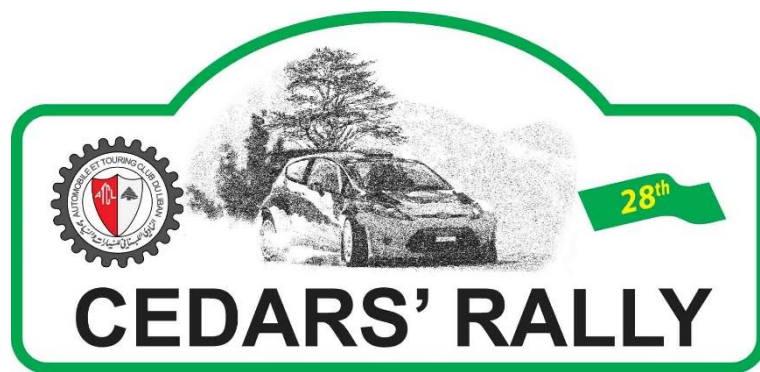

SUPPLEMENTARY REGULATIONS



Organised by

The Automobile and Touring Club of Lebanon
P.O. Box 115 - Jounieh / Lebanon
Tel.: +961-9-640220 / 640567 / 932020
Fax: +961-9-640579 / 934662
e-mail: atcl@inco.com.lb
web site: www.atcl.org



CONTENTS:

	<u>Page</u>
1. Introduction	3
2. Organisation and Description	3
3. Programme and Deadlines	5
4. Entries	6
5. Insurance	11
6. Advertising & Identification Numbers	12
7. Tyres	12
8. Fuel	13
9. Reconnaissance	15
10. Administrative Check	16
11. Scrutineering, Sealing and Marking	17
12. Other Procedures	20
13. Identification of Officials	22
14. Prizes	22
15. Final Checks and Protests	23
APPENDIX 1 Itinerary	25
APPENDIX 2 Reconnaissance schedule	27
APPENDIX 3 Name and photograph of CRO	28
APPENDIX 4 Advertising and Identification Numbers	29
APPENDIX 5 Extracts from FIA Appendix L	31
APPENDIX 6 Mounting of On-Board Cameras	35

1 - INTRODUCTION:

1.1 - Announcement

This rally will be run in compliance with the FIA International Sporting Code (and its appendices), the 2019 FIA Regional Rally Sporting Regulations, the regulations for the 2019 FIA Middle East Rally Championship, the National Sporting Code which comply with the FIA regulations. The Lebanese traffic law shall apply. Unless provided otherwise by these Supplementary Regulations, the provisions of the above Rules and Regulations shall apply.

Modifications, amendments and/or changes to these Supplementary Regulations will be announced only by numbered and dated bulletins (issued by the Organiser or the Stewards).

The 2019 FIA Regional Rally Sporting Regulations can be found at:

<http://www.fia.com/regulation/category/117>

1.2 - Road surface

The rally will be run on **Tarmac**.

1.3 - Overall SS distance and total distance of the itinerary

SS distance: **132.65 kms.**

Total distance: **347.04 kms.**

2 - ORGANISATION AND DESCRIPTION

2.1 – National titles for which the rally counts:

- The 2019 Lebanese Rally Championship for Drivers.
- The 2019 Lebanese Rally Championship for Co-Drivers.
- The 2019 Lebanese Cup for RC2/N4 Rally Drivers.
- The 2019 Lebanese Cup for RC3 Rally Drivers.
- The 2019 Lebanese Cup for RC4 Rally Drivers.
- The 2019 Lebanese Cup for RC5 Rally Drivers.
- The 2019 Lebanese Cup for Junior Rally Drivers/Co-Drivers.
- The 2019 Ladies Cup for the Lebanese Championship.

2.2 - Visa numbers - ASN:

ASN visa No: **R/3/2019**

Issued on: **February 8th, 2019**

2.3 - Organiser's name, address and contact details (permanent office)

The Automobile and Touring Club of Lebanon
Kaslik; Jounieh
National Sporting Committee / Permanent Secretariat
28th Cedars' Rally Office

P.O. Box 115 - Jounieh / Lebanon
Tel.: +961-9-640220 / 640567 / 932020
Fax: +961-9-640579 / 934662
e-mail: atcl@inco.com.lb
website: www.atcl.org



2.4 - Organisation committee:

Chairman	Fady Y. Aoun
Members	George Ferzly Dr. Guy Hokayem Nicolas El Hindi Me Ziad Jamous Raffi Khederlarian Serge Tchopourian

2.5 - Stewards of the Meeting:

Chairman of the Panel	Issam El-Hitti (Chairman) Gaby Hayek Nicolas El Hindi
Secretary to the Stewards	Neveen Hachem

2.6 - Observers and Delegates:

ASN Observer	Gaby Kreiker
--------------	--------------

2.7 - Senior Officials:

Clerk of the Course	Dr. Guy Hokayem
Deputy Clerk of the Course	Me Ziad Jamous
Chief Safety Officer	Roger Sfeir
Scrutineers	Raffi Khederlarian(Chief) Georges Haddad Hovsep Aslanian Khalil Hashem Ardem Sarkissian Anthony Bassil
Competitors' Relations Officer	Nabil Komboz
Chief Medical Officer	Dr. Guy Hokayem
Media Relations Officer	Jalal Beaino
Judges of Fact:	All the Observers and Senior officials named on this page.
Results Officer	Fady Eid
Secretary of the Rally	Joelle Daou

2.8 - HQ location and contact details

The Rally HQ is located at:

Cedrus Hotel
Cedars; Lebanon
E-mail: atcl@inco.com.lb
Web site: www.atcl.org

2.9 - Location of Holding Area and Parc Fermé:

The Start holding area will be located at Cedrus Hotel.

The Parc Fermé will be located at Cedrus Hotel.

2.10 - Location of Service park(s):

The Service Park is located at North College Zghorta.

3 - PROGRAMME AND DEADLINES:

(IN CHRONOLOGICAL ORDER)

Monday July 8th, 2019

10:00hrs	Opening date for entries.	Rally Secretariat A.T.C.L. Jounieh
	Opening date for media accreditation requests.	

Wednesday July 17th, 2019

12:00hrs	Submittal of Fuel Purchase Form.	TOTAL Liban Ashrafieh; Beirut
15:00hrs	Closing date for entries.	Rally Office A.T.C.L. Jounieh
15:00hrs	Closing date for co-driver details. Closing date for submitting all Forms and media accreditations.	Rally Office A.T.C.L. Jounieh
18:00hrs	Publication of the Entry List on the official notice board.	Rally Secretariat A.T.C.L.; Jounieh
18:30hrs	Publication of convocations to administrative checks and scrutineering.	Rally Secretariat A.T.C.L. Jounieh

Thursday July 18th, 2019

09:00hrs	Distribution of media accreditation.	Rally Secretariat A.T.C.L. Jounieh
18:00 till 22:00hrs	Administrative Checks Collection of material and documents Issuing of Road Book collection of The safety tracking devices.	Rally Secretariat A.T.C.L. Jounieh
18.30 till 22.30hrs	Scrutineering - sealing and marking	Tennis Courts Venue A.T.C.L. Jounieh
23:00hrs	First stewards' meeting	Rally Secretariat A.T.C.L. Jounieh

Friday July 19th, 2019

08:00hrs	Reconnaissance starts (2 passages)	
9:30hrs	Publication of Start List.	Official Notice Board
18:00hrs	Reconnaissance ends.	



Saturday July 20th, 2019

13:30hrs	Opening of the Rally Headquarters.	Cedrus Hotel Cedars
15:00hrs – 15:25	Cars entry to the Start holding area.	Cedrus Hotel Cedars
17:55hrs	Rally Start (TC0) Section 1 - Leg 1	Cedrus Hotel Cedars
18:10hrs	Finish Section 1 (Parc Ferme IN)	Cedrus Hotel Cedars

Sunday July 21st, 2019

06:00hrs	Start Section 2 – Leg 1 (Parc Ferme OUT)	Cedrus Hotel Cedars
17:45hrs	Finish Ceremony and Prize-giving. Finish Leg 1	Cedrus Hotel Cedars
18:30hrs	Final Scrutineering.	Cedrus Hotel Cedars
19:00hrs	Publication of the Provisional Final Classification.	Cedrus Hotel Cedars
19:30hrs	Publication of the Official Final Classification.	Cedrus Hotel Cedars

Official Notice Board

- Monday July 7th, 2019 to Friday July 19th, 2019
Rally Secretariat
The Automobile and Touring Club of Lebanon
Kaslik; Jounieh
National Sporting Committee Office
- Saturday and Sunday July 20th and 21st, 2019
Rally Headquarters
Cedrus Hotel
Cedars; North Lebanon

4 - ENTRIES

4.1 – Closing date for entries:

Wednesday July 17th, 2019 at 15:00hrs

4.2 - Entry procedure:

Any person wishing to take part in the 28th Cedar's Rally must complete and send the entry form (including co-driver details) to the Rally Secretariat (for address details please refer to Art. 2.3 of these Supplementary Regulations).

All entry forms must be signed by the entrant and each crew member prior to the start of testing and/or reconnaissance. Foreign competitors must hold an authorisation from their parent National Sporting Authority.

Entry forms will only be accepted if accompanied by:

- The total amount of the entry fees.
- Photocopy of the first page of the homologation book for the car.
- Photocopy of the entrant / competitor licence.
- Photocopies of crew members' competitions licences.
- Photocopies of crew members' valid driving licences.
- A letter from the owner of the car and/or a power of attorney (if the car is not the property of the crew members).

4.3 - Number of entrants accepted and classes:

The maximum number of entries is 40 cars. If more than 40 entries are received, the Organisers reserve the right to decide which entries (among the non-priority drivers) to be accepted.

4.3.1 – Classes and Groups: In accordance with Article 4.1 of the 2019 FIA Regional Rally Sporting Regulations

CLASSES	GROUPS	
RC2	Group R5 (VR5).	Group R5cars conforming to the 2019 Appendix J, Art. 261.
	S2000-Rally: 1.6T engine with a 28mmrestrictor.	– Super 2000-Rally cars (conforming to the 2013 Appendix J, Art. 255A) fitted with a restrictor complying with Art. 255A-5.1.1-b except for the following points: a) the maximum internal diameter of the restrictor is 28 mm. b) The external diameter of the restrictor at its narrowest point must be less than 34 mm. The diameter must be maintained over a distance of 5mm to each side of the narrowest point. – The diameter of the turbo compressor restrictor may be revised by the FIA at any time without notice.
	S2000-Rally: 2.0 Atmospheric.	Super 2000cars(conforming to the 2013 Appendix J, Article 254A).
	Group R4 (VR4) (not eligible in Europe).	Group R4cars conforming to the 2019 Appendix J, Art. 260.
	Group R4 (VR4K).	Cars fitted with R4 Kit conforming to the 2019 Appendix, Art. 260E.
	Group NR4 over 2000cc (current N4).	Group N cars conforming to the 2019 Appendix J, Art. 254.



RC3		R3 (atmo / over 1600cc and up to 2000cc – VR3C and turbo over 1067cc and up to 1333cc –VR3C).	Group R cars conforming to the 2019 Appendix J, Art. 260.
		R3 (turbo / up to 1620cc / nominal– VR3T).	Group R cars conforming to the 2019 Appendix J, Art. 260.
		R3 (diesel / up to 2000cc / nominal– VR3D).	Group R cars conforming to the 2019 Appendix J, Art. 260D.
		Group A over 1600cc and up to 2000cc.	Group A cars conforming to the 2019 Appendix J, Art. 255.
		Super 1600	Group A cars conforming to the 2019 Appendix J, Art. 255.
RC4	RC4A	R2 (atmo over 1600cc and up to 2000cc – VR2C and turbo over 1067cc and up to 1333cc –VR2C).	Group R cars conforming to the 2019 Appendix J, Art. 260.
	RC4B	R2 (atmo over 1390cc and up to 1600cc – VR2B and turbo over 927cc and up to 1067cc – VR2B).	– Group R cars conforming to the 2019 Appendix J, Art. 260. – Group R cars conforming to the 2018 Appendix J, Art. 260 (VR2B homologated before 31/12/2018).
		Kit-car up to 1600cc.	Group A Kit Cars with a corrected cylinder capacity of less than 1600cc on condition that the homologation is accepted by the FIA as eligible for the Championship concerned.
		Group A up to 1600cc.	Group A cars conforming to the 2019 Appendix J, Art. 255.
RC5		R1 (atmo up to 1600cc - VR1 and turbo up to 1333cc - VR1).	Group R cars conforming to the 2018 Appendix J, Art. 260 (VR1A and VR1B homologated before 31/12/2018).
		R1 (atmo up to 1600cc – VR1A/VR1B and turbo up to 1067cc – VR1A/VR1B).	Group R cars conforming to the 2018 Appendix J, Art. 260 (VR1A and VR1B homologated before 31/12/2018).
		Group N up to 1600cc.	Group N cars conforming to the 2019 Appendix J, Art. 254.

4.3.2 –Additional Provisions:

- Cars homologated as Kit cars, where the capacity is between 1400 and 1600 cc, may be accepted if they also comply with Article 255-6.2 “Weight” of Appendix J.
- Two-wheel drive cars equipped with a supercharged diesel engine with a nominal cylinder capacity of less than 2000cc are accepted in Groups A and N.
- For drivers entered with a Super 2000-Rally car complying with 2013 Art. 255A, it will be possible to use lapsed errata without any penalty.
- For Super 1600 homologated cars, it will be possible to use lapsed errata without any penalty.

4.3.3 – ASN Approved Cars:

In compliance with Article 4.3.6 of the 2019 FIA Regional Rally Sporting Regulations, ASN-approved cars:

- will be permitted to take part and be shown in the entry list.
- The drivers and co-drivers of such cars score points in FIA Middle East Rally Championship.
- These cars must, however, comply with the safety requirements as stipulated in Appendix J, Article 253.

FIA and Lebanese ASN seeded drivers are not permitted to drive such cars in the 28th Cedars’ Rally.

4.3.4 - PROMOTION classification

There will be a PROMOTION classification for the Lebanese competitors with the following conditions:

- a) To hold the Lebanese nationality and competition licence.
- b) Not to be F.I.A. priority driver.
- c) Not to be MERC priority driver.
- d) Not to be an A.S.N. priority driver.
- e) The car must be the property of one of the crew members and not the property of any dealer or manufacturer.
- f) Have not been classified among the first 3 during the past two years and the current year at the Rally of Lebanon.

A list of PROMOTION classification will be issued at the same time along with the entry list.

4.4 - Entry fees and entry packages:

4.4.1 The entry fees are as follows:

- a) With the optional advertising proposed by the Organisers
 - * For Private Entrant USD 750. - U.S. \$
 - * For Legal Entrant USD 1, 500. - U.S. \$
- b) Without the optional advertising proposed by the Organisers
 - * For Private Entrant USD 1, 500. - U.S. \$
 - * For Legal Entrant USD 3, 000. - U.S. \$

Private Entrant: For an entry for the 28th Cedars’ Rally to be considered as a private entry, the following conditions must be complied with:



- a) The car entered must be personal property of one of the crew members and the car licence must be in his/her name.
If the car is not the property of one of the crew members, a letter of authorisation from the owner of the car and/or a power of attorney approving the use of the car should be accompanied along with the entry form.
Letters of authorisation and/or powers of attorney dated more than three months before the date of the rally will not be considered.
- b) The entry form must be made in the name of one of the crew members, not in the name of a sponsor or any commercial organisation.
- c) The entrant's competition licence must be in the name of one of the crew members.

Unless all of the above mentioned conditions are met, the entry will not be considered as a private entry and the appropriate entry fees will be liable for payment.

Legal Entrant: The competing car entered by a team, a manufacturer, a company or other legal entity (with legal entrants / competitors licence).

4.4.2 The entry fees specified in Article 4.4.1 (aforementioned) include:

Item	Private Entrants	Legal Entrant
Driver Passes	2	2
Service Personnel Passes	6	12
“Service” plates	1	2
Road Book	1	1

Should additional material deem necessary; it can be ordered from the rally secretariat by using the “Additional materials order form”.

4.4.3 The change of one crew member will be subject to article 21.5 of the 2019 FIA Regional Rally Sporting Regulations. However, an additional fee of 50.- U.S. \$ will be imposed in case of changing a crew member.

4.5 - Payment details:

Entry Fees can be remitted to the Organiser's Bank Account:

Bank: BLOM Bank (Banque du Liban et d'Outre-Mer)
Bank address: Kaslik Branch
Account N°: 023 - 02(300) 067 36 21 - 1 - 6(44037) and to the order of
The Automobile and Touring Club of Lebanon
IBAN: LB21 0014 0000 2302 3000 6736 2116
SWIFT CODE: BLOMBBXX

Any bank charges incurred by a swift transfer must be charged to the sender's account.

Entry fees paid by bank transfer shall simultaneously be advised to the Rally Office by fax and/or e-mail to ensure that payment is received in full prior to the close of entries.

4.6 - Refunds:

Entry fees will be refunded in full:

- a) To candidates whose entry has not been accepted.
- b) In case the 28th Cedars' Rally does not take place.
- c) Organisers may refund up to 30% of the entry fee to those competitors who, for reasons of "force majeure" (duly certified by their ASN), were unable to start in the rally.

5 - INSURANCE

- a) The insurance guaranties the competitors for civil liability towards third parties for a maximum of USD 100.000 as total liability for this event. The insurance cover will come into effect from the start until the end of the rally or at the moment of permanent retirement, disqualification or exclusion.
- b) Beside the insurance provided by the organisers, it is compulsory for all entrants / competitors to have their rally vehicle covered by a third party liability, during their stay in Lebanon.
A copy of the insurance certificate should be presented along with other documents upon administrative checks (refer here under to Art. 10.3 of these Supplementary Regulations).
- c) It is mandatory that all foreign crew members have Motor Sport Personal Accident Insurance valid for Lebanon, or a Prise en Charge issued by the crew members parent ASN. Otherwise, the Organiser will provide such insurance for a premium of 250. - U.S. \$.
- d) The service, management vehicles and reconnaissance vehicles including those bearing special plates issued by the Organisers may never be considered as official participants in the rally. They are therefore not covered by the insurance policy of the rally and will remain the sole responsibility of their owners.
- e) Damages to rally cars as well as liability of a crew member towards the other crew member or car are not covered by the insurance provided by the Organisers.
- f) **Accident Reporting:**
In compliance with Article 40 of the 2019 FIA Regional Rally Sporting Regulations, if a crew is involved in an accident in which a member of the public sustains physical injury, the car must stop immediately, and the procedure, as laid down in Article 40.3.1, must be followed.
The Lebanese traffic law will be complied with in relation to procedures at accidents.
Moreover, it is compulsory for the competitor or his representative to notify the Clerk of the Course and/or the Competitor's Relations Officer(s) in writing, within 4 hours, with the full details including the names and addresses of those involved and witnesses if any.
Any breach of this rule will be reported and will result in a penalty, at the discretion of the Stewards.



6 - ADVERTISING AND IDENTIFICATION

6.1 - Advertising:

- a) The advertising of tobacco products is allowed on the condition of mentioning the required warnings recommended by the Lebanese government according to the Lebanese law at the time of going to print.
- b) Advertising regarding alcoholic beverages is permitted.
- c) The advertising of political, religious and/or social material is strictly forbidden.
- d) Competition numbers, rally plates and advertising shall be affixed on the car before scrutineering. These must be visible through the whole duration of the rally under the pain of penalty (Article 6.2-b of these Supplementary Regulations.).
- e) Spaces set by the Organisers (refer to Appendix 4 of this Supplementary Regulation) must be reserved on the car, if the entrant has accepted the Organiser's optional advertising, unless he pays the Entry Fees without Optional Advertising proposed by the Organisers in accordance with Article 4.4.1-b of this Supplementary Regulation.

6.2 - Identification numbers:

- a) The rally plates and numbers will be provided by the Organisers in compliance with the FIA Regional Rally Sporting Regulations. These numbers must be affixed as specified in Appendix 4.
- b) The missing and/or covering of a rally plate will result in a cash penalty of 100. - U.S. \$
- c) Service and/or auxiliary vehicle plates shall be affixed on the inside of the windscreen in the top right hand corner.

7 – TYRES

- a) All tyres must comply with Article 60 of the 2019 FIA Regional Rally Sporting Regulations read in conjunction with Appendix V, Article A - Tarmac Tyre Regulations.
The list of eligible asphalt tyres for FIA rallies, which are the only tyres allowed, can be found on the FIA website under the following link:
<http://www.fia.com/regulation/category/117>
- b) In accordance with Article 60.1.6 of the 2019 FIA Regional Rally Sporting Regulations, the use of any device for maintaining the full performance of the tyre with an internal pressure equal to or less than atmospheric pressure is forbidden. The interior of the tyre (the space between the rim and the internal part of the tyre) must be filled only with air.
- c) In accordance with Article 60.13 of the 2019 FIA Regional Rally Sporting Regulations, all tyres used in this rally must be readily available commercially.
- d) Tyre changes may only be carried out in authorised zones.

- e) Tyre marking zones will be organised after the exit TC of the Service Park.
- f) Any breach of the tyre regulations will be submitted to the Stewards and may result in a penalty, which may go as far as the exclusion of the crew by the Stewards.

8 – FUEL

8.1 Fuel supply

8.1.1 - Throughout the 28th Cedars Rally all entered cars shall **SOLELY** use fuel supplied by “TOTAL Liban”, which meets the technical requirements of FIA Appendix J.

8.1.2 - Two types of petrol are available:

- a) ELF TURBO REF (50 litre canisters), sold at the price of \$ **7.70** /litre VAT included.
- b) TOTAL EXCELLIUM 98 octane, sold at current price of the market at delivery time, VAT included.

“TOTAL Liban” will supply the fuel needed for the adjustments, against request and upon payment.

8.1.4 - Closing date for ordering fuel

- a) Each competitor must fill in and submit the special Fuel Purchase Form requesting the quantity of fuel needed for the rally and send it, no later than 12:00hrs on Wednesday July 17th, 2019, to:

TOTAL Liban
Tilal Beirut Bldg., 2nd floor
Rue Ashrafieh
Ashrafieh; Beirut; Lebanon
P.O. Box 11-3636 - Beirut / Lebanon
Tel.: +961-1-212250 Fax: +961-1-216014
e-mail: michel.hajjar@total-liban.com

- b) Payment details:

Payments can be remitted to the supplier’s bank account:

Bank: Bank Audi
Bank address: Centre SOFIL, Ashrafieh Branch
IBAN: LB86 0056 0002 0206 7421 0020 0936
Devise: USD
SWIFT CODE: AUDBLBBX

Any bank charges incurred by a swift transfer must be charged to the sender's account.

Moreover, a copy of fuel purchase invoice should be presented along with other documents in the administrative checks.

In case of failure to collect part of the fuel, the purchaser will be refunded with the corresponding amount of the remaining fuel in sealed canisters ONLY for TURBO REF Type, within 15 days after the end of the rally.



8.1.5 Fuel dispense

The fuel will be dispensed to the competitor or his representative (duly assigned in writing) at the refuelling zone – as indicated in the Road-Book - subject to presenting the voucher given by “TOTAL Liban” and in compliance with the schedule filled on the Fuel Purchase Order and mutually agreed upon between “TOTAL Liban” and the purchaser.

It is the competitors’ responsibility to fill the appropriate form given by TOTAL Liban regarding the quantity to be dispensed at each of the refuelling zones in the rally.

8.2 General provisions

- a) Only UNLEADED fuel is admitted in Lebanon.
- b) The fuel tank capacity should meet and cover the time and distance table of the rally, *i.e. the rally itinerary*.
- c) Except as detailed under Article 50 and in accordance with Article 58 of the 2019 FIA Regional Rally Sporting Regulations, competitors may only refuel in the refuel zones designated by the Organisers in the road-book. Other activities inside the refuelling zone are strictly prohibited.

Any breach of these regulations will be reported to the Stewards who may apply penalties at their discretion which may go as far as the exclusion of the crew.

- d) Refuelling procedure (Article 58 of the 2019 FIA Regional Rally Sporting Regulations):
 - Only actions inside a refuelling zone directly involved in the refuelling of the competing vehicle are permitted.
 - In all refuelling zones, a 5 kph speed limit will apply.
 - The responsibility for refuelling is incumbent on the competitor alone.
 - It is **MANDATORY** for the relevant personnel for the refuelling to be wearing clothing which will provide adequate protection against fire.
 - Engines must be switched off throughout the refuelling operation.
 - It is recommended that the crew remains outside the car during refuelling; however, should they remain inside, their safety belts must be unfastened.
 - Solely for the purpose of assisting with the refuelling procedure of their car, two team members of each crew may access this zone.
 - A car may be pushed out of the zone by the crew, officials and/or the two team members without incurring a penalty.
- e) The organisers may make provisions for additional refuelling zones. However, these additional zones shall only be positioned along the itinerary. Except for refuelling rally vehicles, any other kind of servicing is strictly prohibited.

Any breach of the fuel and/or refuelling regulations will be submitted to the Stewards and may result in a penalty, at their discretion, which may go as far as the exclusion.

9 - RECONNAISSANCE

9.1 - Procedure for registration:

- a) Reconnaissance Cars must be in conformity with Article 25.1 of the 2019 FIA Regional Rally Sporting Regulations, and must be covered by insurance as required by the traffic laws of Lebanon, no responsibility being imputable to the organisers.
- b) When registering for reconnaissance, one of the crew members must be present to sign an indemnity and register the details of the reconnaissance car (spare recce car, if any), mobile telephone number and contact details of the place of residence.
- c) The Reconnaissance Registration Form can be collected from the Rally Secretariat or downloaded from the A.T.C.L. official website. This form should be filled and sent to the Rally Secretariat before commencing the reconnaissance.

9.2 – Reconnaissance Schedule:

The road book will be issued on Thursday, July 18th, 2019, and will be distributed between 18:00 and 22:00hrs.

The Reconnaissance Schedule starts on Friday, July 19th, 2019, at 8:00hrs time and ends at 18:00hrs. of the same day.

The reconnaissance is limited to two passages only, per super stage.

Any competitor found in breach of this rule, will be reported to the stewards who may apply penalties at their discretion.

9.3 - Specific and national restrictions – speed limit:

- a) Reconnaissance outside the aforementioned Reconnaissance Schedule, Article 9.2 of this Supplementary Regulation, as from the dates of publication of the itinerary on the A.T.C.L official website, to the date and time of the Start of the Rally is **PROHIBITED**. The presence of any driver or co-driver, or any other team member who has entered or intends to enter in the 28th Cedars Rally, outside the Reconnaissance Schedule, on any part of a special stage to be used in the rally, in any way whatsoever, is considered as illegal reconnaissance, and a breach of this supplementary regulations; he or she will be reported to the stewards who may apply penalties at their discretion.
- b) Crews will only be permitted to enter and leave special stages through the start and finish controls shown in the Road Book and may not under any circumstances drive in a direction opposite to that of the rally.
- c) **Maximum speed limit of 50 km/h during reconnaissance is imposed on all special stages, 30 km/h inside villages**, unless another speed limit is indicated by traffic signs. In compliance with Article 20.2.2 of the 2019 FIA Regional Rally Sporting Regulations, speeding during reconnaissance will incur a fine applied by the clerk of the course as follows:
 - Per km per hour over the speed limit: **€ 25**

The amount of this fine will be unaltered by any fine imposed by the police.



The fine will be doubled in case of a second offence committed during reconnaissance in the same rally.

Other traffic infringements during reconnaissance will incur a fine applied by the Stewards.

- d) **All cars must have their headlights on at all times whilst travelling on the special stages.**
- e) Any breach of the reconnaissance regulations, of the 2019 FIA Regional Rally Sporting Regulations and these Supplementary Regulations, will result in a penalty, which may go as far as exclusion, at the discretion of the Stewards.

9.4 - Fitment of speed control checking devices:

It is emphasized that reconnaissance is not a practice run. The competitors must drive in a manner that does not endanger or cause inconvenience to traffic or people living within and near the stages. During reconnaissance, the traffic laws of Lebanon must be strictly complied with as well as the safety and rights of ways of other road users should be respected.

The police may check the speed on the road sections and the special stages using speed check equipment.

9.5 - Comment on tyres:

Complying with Article 25.2.a of the 2019 FIA Regional Rally Sporting Regulations, road-homologated series production tyres for asphalt are to be used for reconnaissance.

Any breach of the reconnaissance regulations, will result in a penalty at the discretion of the Stewards, which may go as far as disqualification. Furthermore, the Stewards may report the competitors concerned to the CSN for possible further sanctions.

10 - ADMINISTRATIVE CHECKS

10.1 - Location:

Administrative checks will take place on Thursday, July 18th, 2019 at the:

Rally Secretariat
A.T.C.L. Jounieh

Both crew members have to attend the administrative check. However, Legal Entrants as well as FIA, MERC and ASN priority drivers may appoint a representative and/or a team manager (duly assigned in writing) for their entries.

10.2 - Times / schedule:

From 18:00hrs till 22:00hrs, according to an individual time schedule given later in a bulletin or a communication and posted on the official notice board at The Automobile and Touring Club of Lebanon; Jounieh - Lebanon.

Any crew reporting outside their time limits for Administrative Checks will be penalized 15. - U.S. \$ per minute to maximum of 15 minutes. Thereafter, they will be reported to the Stewards who may apply penalties at their discretion.

10.3 - Documents to be presented:

The following items will be checked at Administrative Checks:

- Entrants' licence (if any).
- Drivers' and Co-drivers' competition licences.
- Valid drivers' and Co-drivers' driving licences.
- Rally car documents and registration papers etc...

If the car is not the property of one of the crew members, a letter of authorisation from the owner of the car and/or a power of attorney approving the use of the car should be accompanied along with the entry form.

Letters of authorisation and/or powers of attorney dated more than three months before the date of the rally will not be considered.

- Insurance policy covering the rally vehicle (refer to Art. 5.b of these Supplementary Regulations.
- Motor Sport Personal Accident Insurance (Refer to Art. 5.c of these Supplementary Regulations.
- Copy of fuel purchase invoice.
- Correctness and completion of all information given on the entry form.
- Authorisation for the drivers by their ASN to take part in the rally should be presented.
- Drivers' and co-drivers' medical certificates of aptitude valid for the current year as given to them by their parent ASN. These certificates must be in accordance with the ISC Appendix L, Chapter II, Article 1.8.

Competitors are required to hold a signed Administrative Clearance Form prior to Scrutineering.

11 - SCRUTINEERING, SEALING AND MARKING

The Administrative Check must be completed prior to Scrutineering. Competitors are required to present their signed Administrative Clearance Form prior entering the Scrutineering venue.

11.1 - Location:

Scrutineering, Sealing and Marking will take place on Thursday, July 18th, 2019 at the:

Rally Secretariat
A.T.C.L. Jounieh

Both crew members have to attend the Scrutineering. However, Legal Entrants as well as FIA, MERC and ASN priority drivers may appoint a representative and/or a team manager (duly assigned in writing) for their entries.

Times / schedule:

From 18.30hrs till 22.30hrs, according to an individual time schedule given later in a bulletin or a communication and posted on the official notice board at the Automobile and Touring Club of Lebanon; Jounieh - Lebanon.



Any crew reporting outside their time limits for Scrutineering will be penalized 15. - U.S. \$ per minute to maximum of 15 minutes. Thereafter, they will be reported to the Stewards who may apply penalties at their discretion.

11.2 - Windows/Nets:

In compliance with the traffic law of Lebanon, **the use of silvered or tinted film is NOT AUTHORISED** on the side as well as the rear windows.

However, and in compliance with Appendix J, Article 253.11, the use of transparent and colourless anti-shatter films on the side windows and the glass sunroof is mandatory.

11.3 - Driver's safety equipment:

- The control of drivers' helmets and equipment as well as the head restraint (FHR device) will take place at the scrutineering. The helmets must meet one of the standards listed in technical list No. 25 of Appendix J. Each helmet used by the crew will have to be identified and marked during the scrutineering before start. This marking may be checked on the start and/or finish of each special stage.

Drivers 'and co-drivers' overalls as well as gloves (optional for co-drivers), long underwear, a balaclava, socks and shoes should be homologated to FIA 8856-2000 standard (Technical List N°27) or FIA 8856-2018 standard (Technical List No 74), of Appendix J.

- In compliance with ISC Appendix L, Chapter III, Article 3, the wearing of an FIA approved Frontal Head Restraint (FHR), homologated according to the FIA 8858 standard, on special stages is **MANDATORY** for all drivers and co-drivers. Homologated FHR systems are listed in the FIA Technical List N° 29.
- In compliance with Appendix L, Chapter III, Article 2, the wearing of flame-resistant clothing, homologated to the FIA 8856-2000 or FIA 8856-2018 standards, on special stages is **MANDATORY** for all drivers and co-drivers.
- Infringements are subject to the penalty of refusal to take the start.
- In compliance with ISC Appendix J, Article 253.8.4, where the occupants' bodies could come into contact with the safety cage, flame retardant protective padding must be provided for protection. All tubes of the cage and all roof reinforcements must be fitted with paddings in compliance with FIA standard 8857-2001 type A; *refer to Technical List No. 23*. Each padding must be fixed in such a way that it is not moveable from the tube.

11.4 - Scrutineering requirements:

- Cars must be presented to the scrutineers with the competition numbers, rally plates and optional advertising affixed on the car before entering the Scrutineering venue. Failing to comply with this rule is subject to a cash penalty of 100. - U.S. \$ (Article 6.2.b of these Supplementary Regulations).
- In accordance with Article 26.1.4 of the 2019 FIA Regional Rally Sporting Regulations **the presentation of the car's complete original FIA**

homologation form in scrutineering is compulsory. Any breach of these regulations will be reported to the Stewards who may apply penalties at their discretion.

- **It is MANDATORY for ALL vehicles to be provided with APPROVED SAFETY FUEL TANKS (FT3-1999, FT3.5- or FT5-1999) and connections that are in compliance with the specifications set in Article 253.14, Appendix J of the 2019 FIA International Sporting Code.**
- In accordance with Appendix J, Article 253.6, two belt cutters must be carried on board at all times. They must be easily accessible for the driver and co-driver when seated with their harnesses fastened.
- An authentic copy of the homologation document or certificate, of the roll cage approved by the ASN and signed by qualified technicians representing the manufacturer, must be presented to the event's scrutineers
- **Lighting:**
In accordance with Appendix J of the International Sporting Code, a maximum of 6 additional headlights including the corresponding relays are allowed.
If the series fog lamps are kept, they will be counted as additional headlights.
- **In accordance with Appendix J, Article 252-3.6, “all cars used in Rallies ..., the noise level on the open road must not exceed 103 dB(A) for an engine rotation speed of 3500 rpm for petrol engines”.**
- In accordance with Article 40.2 of the 2019 FIA Regional Rally Sporting Regulations, each competing car shall carry a red “SOS” sign and on the reverse a green “OK” sign measuring at least 42 cm x 29.7 cm (A3).
- In accordance with Appendix A, Chapter X, Article 5, of the National Sporting Code, all Competitors, teams and entrants who wish to carry on-board cameras, in-car videos and/or film cameras must have the prior agreement of the Organisers. **However, it is MANDATORY to provide the Organisers and/or the Clerk of the Course with a copy of the complete unedited recordings upon requisition with no delay.**
Authorised cameras will be identified by an adhesive decal and must be mounted in/on the car at the time of scrutineering. The mounting of on-board cameras (Interior/Exterior) to be in compliance with Appendix 7 of this Supplementary Regulations.
The On-Board Camera Application Form can be collected from the Rally Secretariat or downloaded from the ATCL official website. This form should be filled and sent to the Rally Secretariat by **Wednesday July 17th, 2019 at the latest.**
Failing to observe this rule will be subject to a penalty at the discretion of the Stewards of the Meeting.



12 – OTHER PROCEDURES

12.1 - Ceremonial start:

Ceremonial start is not scheduled for the 28th Cedars' Rally.

12.2 - Official start:

The start of the Rally (TC 0) will take place at the Cedrus Hotel, Cedars, followed by a Super Special Stage on July 20th, 2019 at 18:00hrs.

Competitors reporting late to the start area will be penalized 15.- U.S. \$ per minute to a maximum of 15 minutes. Thereafter, Article 44.2 of the 2019 FIA Regional Rally Championships Sporting Regulations will apply.

12.3 - Super special stage:

Two Super Special Stages (SS 1 and SS11) will be run during the 28th Cedars' Rally.

The competitors will individually run one laps around a street stage, covering the total distance of 1.57kms.

The competitors will run individually on the super special stage as per their official designated time in an ascending numerical sequence, from first to last. The course will be run in a counter-clockwise direction.

The organisers reserve the right to seed the competing vehicles at their own discretion, on grounds of public and media interest.

The maximum time allowed to complete the Super Special Stage - SS1 and SS11 will be 4 minutes.

Any crew who fails SS1 within the maximum time allowed or does not start this stage, will be subject to the penalties as per Article 46.2.2 of the 2019 FIA Middle East Rally Championship Sporting Regulations.

If the running of this Super Special Stage is interrupted, a red flag will be displayed to the crews, who must immediately reduce speed and follow the marshals' instructions. Failing to comply with this rule will entail a penalty at the discretion of the Stewards. However, and in accordance with Article 5.5.4.3.f of Appendix III of the 2019 FIA Regional Rally Sporting Regulations, a red flag signal may be replaced by a flashing red light.

If a car fails to correctly complete the super special stage, it will be removed **IMMEDIATELY** by the Organisers to the nearest place out of the circuit.

At all times Competitors must follow the officials' instructions.

12.4 - Finish procedure:

The Rally will conclude at the Finish Podium situated at the Cedrus Hotel, Cedars, on Sunday July 21st, 2019 at 18:00hrs. Competitors shall follow the Officials directions to the finish ramp, directly followed by the final Parc Fermé.

After clearing the finish ramp, the crews shall drive their cars, as instructed by the officials to the final Parc Fermé and/or scrutineering.

However, each crew may nominate a representative, duly assigned by writing, to take delivery of the car out of the final Parc Fermé. In the event that the car is not driveable this shall be reported to the Clerk of the Course and/or the Competitors' Relations Officer; the crew is solely responsible to arrange transport by a recovery vehicle on his own cost and in a timely manner.

12.5 – Permitted Early check-in:

Crews are authorised to check in early without incurring a penalty at:

TC 1 A	End of section 1 / Parc Fermé IN.
TC 11A	End of Leg 1 / FINISH holding area IN.

12.6 - Special procedures / activities:

12.6.a - Starting system:

The timekeeping in the special stages will be carried out to the 1/10th of a second.

The start of the special stages will be carried out by an electronic countdown system, placed on the left hand side of the road, between 2 and 5 meters ahead of the starting line, counting down by seconds and clearly visible to the crew from the start position.

This system is electronically coupled to a start line detection device that records any situation where a car leaves the start line ahead of the correct signal. This system may also be synchronized with a starting lights system of which the description and regulations will be included if appropriate in a bulletin.

Should the above starting light panel fail to function; the start will be given in accordance to Article 37.3 of the 2019 FIA Regional Rally Sporting Regulations.

12.6. b - Starting order and interval:

- a) The starting order will be determined as follows:
 - FIA priority drivers
 - MERC priority drivers
 - Lebanese ASN priority drivers - Rallies
 - Other drivers
- b) All drivers will have an interval of one minute (**1min.**) between their start times.

12.6. c - Time card change during the rally:

The Time Cards will be issued at the following time controls:

- Section 1 TC 0 Start Section 1 / Leg 1
- Section 2 TC 1B Start Section 2 / Leg 1
- Section 3 TC 4B Regrouping OUT / Service B IN
- Section 4 TC 7B Regrouping OUT / Service C IN
- Section 5 TC 10B Holding Area OUT

When retiring, the crew are obliged to hand their time card either to the next time control or otherwise to the Sweeper car.

12.7 - Official time:

The official time throughout the entire rally will be based on GPS time (UTC +3 hours).

A display of the “Official Time” will be located at the event headquarters as well as on the starting podium.

12.8 - Interruption of a Super Special Stage /Special Stage:

If a Super Special Stage /Special Stage is interrupted or stopped for any reason, article 39 of the 2019 FIA Regional Rally Sporting Regulations will apply.



12.9 - Re-Start after retirement regulations:

Re-Start after retirement regulations will be carried out in compliance with Article 46 of the 2019 FIA Middle East Rally Championship

12.10 - Excessive speed during the rally:

In compliance with Article 20.3 of the 2019 FIA Regional Rally Sporting Regulations, speeding during the rally will incur a fine applied by the clerk of the course as follows:

- € 25 per km per hour over the speed limit.

The amount of this fine will be unaltered by any fine imposed by the police.

13 - IDENTIFICATION OF OFFICIALS

The post chiefs and other officials will be identified as follows:

Senior Rally Officials	White shirts with their names in dark blue letters on their left.
Competitors' Relations Officers	Pink shirts with "C.R.O." in large white letters weaved on their back.
Headquarters staff	Light grey shirts.
Media staff	Light yellow shirts.
Stages Commanders	Blue shirts baring the A.T.C.L logo on it.
Stages Safety Officers	Navy blue shirts with "SAFETY" weaved on their back.
Scrutineers	Black tabards with "SCRUTINEER" in white.
Stages Time Control Officers	Yellow tabards with "TEAM LEADER" in blue.
Special Stages posts chiefs	Yellow tabards with "TEAM LEADER" in blue.
Stages Doctors	Bright red tabards with "DOCTOR" in black.
Safety Marshals	Bright yellow tabards with "SAFETY" in grey.
Intermediary and Radio Points	Bright yellow tabards with blue radio point symbol.
Red flag marshals	Bright orange tabards with black radio point symbol.
Special Stages Marshals	Blue tabards with "MARSHALS" in white.

14 - PRIZES

14.1 - Prize-giving:

- a) The prize giving shall take place on the podium at the finish ramp situated in fr on Sunday, July 21st, 2019 at 17:45hrs.

- b) Competitors that are not personally present at the prize giving ceremony will lose their right to the prizes that are theirs. Nevertheless, the classification and attribution of the other prizes won't be modified.

14.2 - Prizes:

List of prizes and cups:

- a) General Classification:
- | | |
|--------|-------------|
| First | 2 Trophies. |
| Second | 2 Trophies. |
| Third | 2 Trophies. |
- b) Class RC2/N4 Cup 2 Trophies (1st crew).
- c) Class RC3 Cup 2 Trophies (1st crew).
- d) Class RC4 Cup 2 Trophies (1st crew).
- e) Class RC5 Cup 2 Trophies (1st crew).
- f) Promotion Classification: 2 Trophies (1st in Promotion Classification, as per these Supplementary Regulations, Article 4.3.4).
- g) Junior Drivers/Co-Drivers Cup 2 trophies, 1st junior crew in the general classification.
- h) Ladies Cup: 2 Trophies, 1st Female Crew.
- i) All finishers: 2 Medals.

The Junior Drivers/Co-Drivers Cup will be awarded to the first junior driver and co-driver in the general classification registered for the 28th Cedars' Rally. In compliance with Article 12, Appendix A of the 2019 National Sporting Code to qualify for this cup, the following conditions will apply:

- The Driver/Co-Driver must have his/her 26th birthday after the end of the current year.
- The Driver/Co-Driver must be driving a 2WD cars of class RC3, RC4 and RC5.
- The driver and co-driver may not necessarily be members of the same crew.

15 - FINAL CHECKS AND PROTESTS

15.1 - Final checks:

The final scrutineering will take place at the Cedrus Hotel, Cedars, on Sunday, July 21st, 2019 at 18:30hrs.

Cars subject to final checks (decision by the Stewards upon the recommendation of the Chief Scrutineer) must have one representative for the entrant as well as two mechanics, in case of dismantling, present at the final check.

15.2 - Protest and Protest Deposits:

- a) Accompanied with the protest deposit, all protests must be lodged in writing and handed to the clerk of the course within the time set in Article 13 of the 2019 International Sporting Code.



-
- b) In compliance with Article 55 of the 2019 FIA Regional Rally Sporting Regulations, each protest deposit is set at € **1,000**, which shall not be returned if the protest is judged unfounded.

If the protest requires the dismantling and the re-assembly of different part of a car, the claimant must pay an additional deposit:

- i. If the protest involves a clearly defined part of the car (engine, transmission, steering, braking system, electrical installation, bodywork, etc.): USD2,000 per each.
 - ii. Protests involving the whole vehicle are inadmissible.
- c) The expenses incurred in the work and in the transport of the vehicle shall be borne by the claimant if the protest is unfounded, or by the competitor against whom the protest is lodged if the claim is founded.
- d) If the claim is unfounded, and if the expenses incurred by the protest (scrutineering, transport etc.) are higher than the guarantee deposit, the difference shall be borne by the claimant.

Conversely, if the expenses are less, the difference shall be returned to him.

15.3 - Appeal deposit:

- a) The sum of the National appeal deposit (ASN): **USD 4000**

APPENDIX 1: ITINERARY OF THE RALLY

28th CEDARS' RALLY

Version (2), July 7th, 2019

Saturday July 20th, 2019

LEG 1						
TC	LOCATION	SS dist.	Liaison dist.	Total dist.	Target time	First due
0	Start Leg 1 – Cedrus Hotel; Cedars	-	-	-	-	17:55
1	Cedars	-	1.01	1.01	00:02	17:57
<i>SSI</i>	<i>CEDARS SUPER SPECIAL STAGE 1</i>	<i>1.57</i>	-	-	-	18:00
1A	Parc Fermé IN – Cedrus Hotel; Cedars	-	1.83	3.40	00:10	18:10
<i>Early Check IN Permitted</i>						
Cedrus Hotel; Cedars		1.57	2.90	4.47		
OVERNIGHT PARC FERME						

Section 1

Saturday July 20th, 2019: Dawn: 04:01hrs.
Sunrise: 05:41hrs.
Sunset: 19:47hrs.



RE-START LEG 1							Sunday July 21 st , 2019						
TC	LOCATION	SS	Liaison	Total	Target	First							
		dist.	dist.	dist.	time	due							
Re-Start Leg 1 - Section 2, Cedrus Hotel; Cedars													
1B	Parc Fermé OUT	-	-	-	-	06:00							
1C	Service IN	-	43.55	43.55	01:00	07:00							
Service A – North College; Zgharta		-	43.55	43.55	00:15								
1D	Service OUT	-	-	-	-	07:15							
RZ 1	Refuel – North College; Zgharta	1.57	46.45	48.02									
	Km to run before RZ 2	43.17	61.70	104.87									
2	Bhabbouch	-	16.69	16.69	00:23	07:38							
SS2	BHABBOUCH 1	9.21	-	-	-	07:41							
3	Khaldieh	-	29.45	38.66	00:52	08:33							
SS3	KHALDIEH 1	19.92	-	-	-	08:36							
4	Miziara	-	5.34	25.26	00:34	09:10							
SS4	MIZIARA 1	14.04	-	-	-	09:13							
4A	Regrouping & Technical Zone IN	-	10.22	24.26	00:34	09:47							
4B	Regrouping OUT / Service IN	-	-	-	00:15	10:02							
Service B – North College; Zgharta		43.17	61.70	104.87	00:30								
4C	Service OUT	-	-	-	-	10:32							
RZ 2	Refuel – North College; Zgharta	43.17	61.70	104.87									
	Km to run before RZ 3	43.17	61.70	104.87									
5	Bhabbouch	-	16.69	16.69	00:23	10:55							
SS5	BHABBOUCH 2	9.21	-	-	-	10:58							
6	Khaldieh	-	29.45	38.66	00:52	11:50							
SS6	KHALDIEH 2	19.92	-	-	-	11:53							
7	Miziara	-	5.34	25.26	00:34	12:27							
SS7	MIZIARA 2	14.04	-	-	-	12:30							
7A	Regrouping & Technical Zone IN	-	10.22	24.26	00:34	13:04							
7B	Regrouping OUT / Service IN	-	-	-	00:15	13:19							
Service C – North College; Zgharta		43.17	61.70	104.87	00:30								
7C	Service OUT	-	-	-	-	13:49							
RZ 3	Refuel – North College; Zgharta	43.17	61.70	104.87									
	Km to run before FINISH	44.74	88.09	132.83									
8	Bhabbouch	-	16.69	16.69	00:23	14:12							
SS8	BHABBOUCH 3	9.21	-	-	-	14:15							
9	Khaldieh	-	29.45	38.66	00:52	15:07							
SS9	KHALDIEH 3	19.92	-	-	-	15:10							
10	Miziara	-	5.34	25.26	00:34	15:44							
SS10	MIZIARA 3	14.04	-	-	-	15:47							
10A	Cedrus Hotel - Holding Area IN		33.71	47.75	00:58	16:45							
10B	Cedrus Hotel - Holding Area OUT				00:10	16:55							
11	Cedars	-	1.07	1.07	00:05	17:00							
SS11	CEDARS SUPER SPECIAL STAGE 2	1.57	-	-	-	17:03							
11A	Finish Holding Area IN - Cedrus Hotel	-	1.83	3.40	00:10	17:13							
							Early Check IN Permitted						
Finish of the Rally - Cedrus Hotel - Cedars		44.74	88.09	132.83									

Sunday, July 21st, 2019: Dawn: 04:02hrs.
Sunrise: 05:41hrs.
Sunset: 19:46hrs.

Section 2

Section 3

Section 4

Sec. 5

TOTALS OF THE RALLY						
		SS	Liaison	Total		%
Saturday July 20 th , 2019	Section 1	1.57	2.90	4.47	% of	35.12%
Sunday, July 21 st , 2019	Sections 2, 3, 4 & 5	131.08	211.49	342.57	SS	38.26%
TOTAL – 11 Special Stages		132.65	214.39	347.04		38.22%

APPENDIX 2:

RECONNAISSANCE SCHEDULE

ALL COMPETITORS
Start: Friday, July 19th, 2019, at 8:00hrs
End: Friday, July 19th, 2019, at 18:00hrs
SS 1 / 11 - Cedars
SS 2 / 5 / 8 - Bhabouch
SS 3 / 6 / 9 - Al Khaldyeh
SS 4 / 7 / 10 - Miziara

- It is emphasized that reconnaissance is not a practice run. The competitors must drive in a manner that does not endanger or cause inconvenience to traffic or people living within and near the stages.
- Maximum speed limit of 50 km/h during reconnaissance is imposed on all special stages, 30 km/h inside villages, unless another speed limit is indicated by traffic signs.
- All cars must have their headlights on at all times whilst travelling on the special stages.**
- The reconnaissance is limited to **Two PASSAGES ONLY**, per super stage.
- The Super Special Stage Reconnaissance will run under the same conditions above.**

Any competitor found in breach of these rules, will be reported to the stewards who may apply penalties at their discretion.

APPENDIX 3:

COMPETITORS' RELATIONS OFFICER

The Competitors' Relations Officer is:



Nabil Komboz

The Competitors' Relations Officer will be easily identified by his Pink shirt with "C.R.O." in white letters weaved on his right.

PRESENCE DURING THE RALLY:

When the Secretariat is opened, a planning of the places and schedule where he will be on duties will be established. This planning will be post on the Official Notice Board and will include:

- Presence at Documentation and Scrutineering
- At the Secretariat of the Meeting.
- At the Start of the Rally.
- At the Regrouping halts.
- At the Service Parks.
- Near the Parc Fermé(s) and the Finish (the latter being dependent on the rally timetable).

FUNCTION:

The principal duty of the CRO is to provide information or clarifications in connection with the regulations

MEDIATION:

- Avoid forwarding questions to the stewards which could be solved satisfactorily by a clear explanation with the exception of protests (for example, clarify disputes over times, with the assistance of the time-keepers).
- The Competitor's Relations Officer shall refrain from saying anything or taking any action which might give rise to protests.

APPENDIX 4:

IDENTIFICATION NUMBERS, ADVERTISING AND NAMES

Identification Numbers and Compulsory Advertising:

- 1 2 x Door Panel with Competition Number 67x17cm. The top of the plate shall be placed between 7 cm and 10 cm below the bottom window line. No other signage shall be placed within 10 cm of the plate. (1)

(Roof Panel (2) not applicable during the 28th Cedars' Rally)

- 2 Rear window panel with Competition Number 30x10cm. It shall be positioned at the top of the rear window in a central location. An adjacent area of 15x15cm containing a 14cm high Competition Number coloured in fluorescent orange (PMS 804). The number must be visible from the rear at eye level. (3)
- 3 Front rally plate 43x21.5cm. (4)
- 4 Rear side windows: (5)
2 x Competition Number 20 cm high with a stroke width of 25 mm coloured in fluorescent orange (PMS 804) shall be placed on the rear side windows adjacent to the crew's name.

The name of the driver with his/her passport nationality national flag must appear on the rear side window of both sides of the car (under the Competition Numbers). The Surname alone shall be:

- 5.1 In Helvetica upper case for the first letter of the name and the remainder in lower case
- 5.2 In white on a clear background.
- 5.3 To a height of 6cm. and a stroke width of 1.0cm.

Organisers' Optional Advertising:

- 1 A 10cm. high strip on the upper part of the windscreen, according to Article 16.7 of the 2019 International Sporting Code (6).
- 2 One space on each Front Door of the vehicle (67cm x 17cm) situated 10cms beneath the Door Panel (7).

A FURTHER BULLETIN WILL DETERMINE THE ADVERTISING BRANDS.

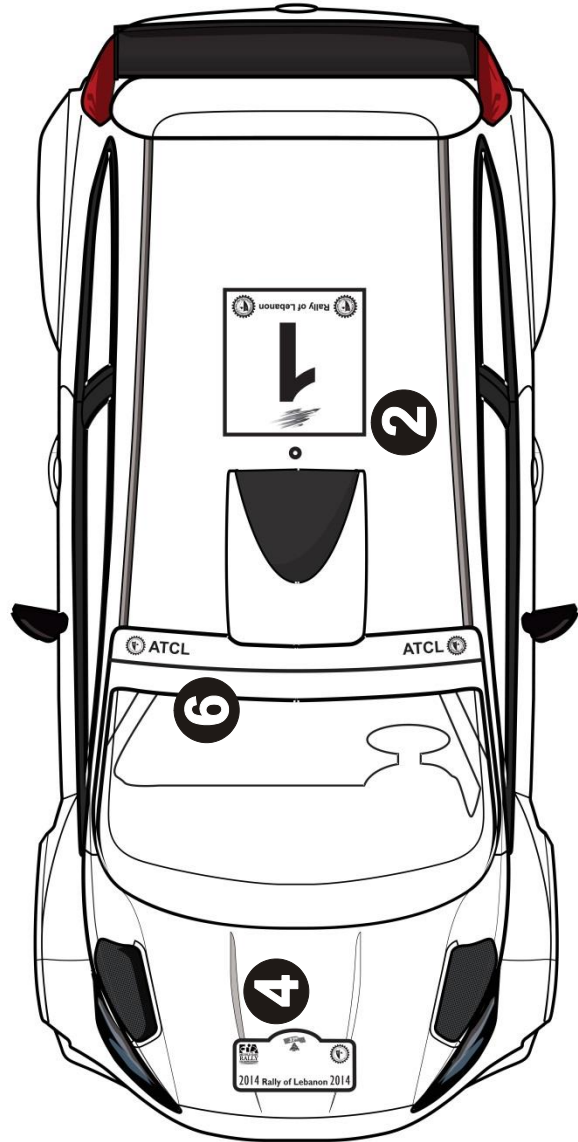
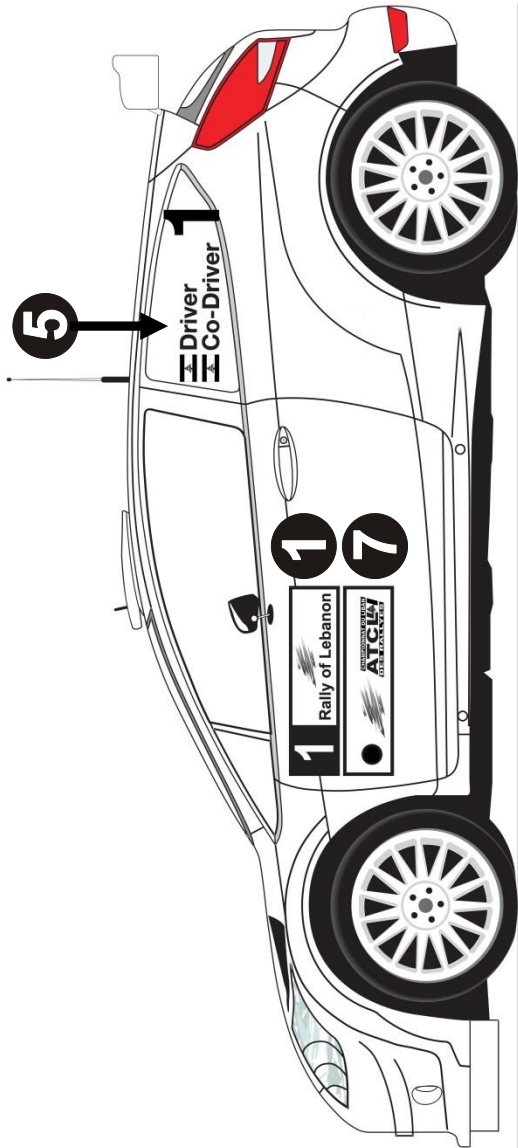
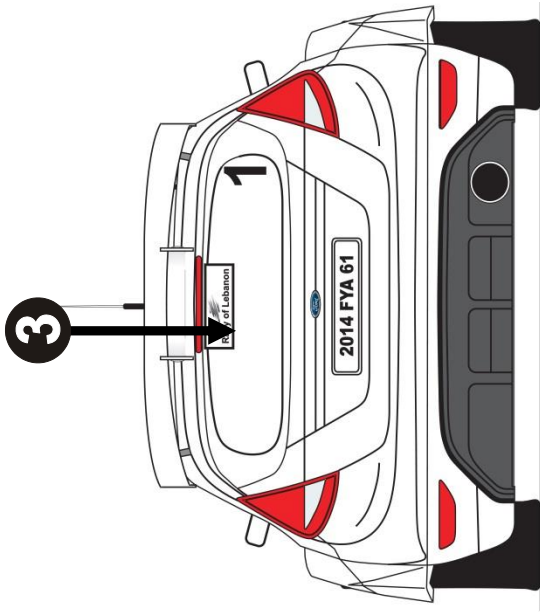

APPENDIX 5:

EXTRACTS FROM FIA APPENDIX L

CHAPTER III - DRIVERS' EQUIPMENT

Article 1- Helmets

When the use of an FHR, according to Article 3 below, is mandatory, drivers competing in circuit competitions, hill climbs or rally special stages, registered on the FIA Calendar, must wear crash helmets homologated to one of the following FIA standards:

- 8858-2002 or 8858-2010 (Technical List N°41),
- 8859 (Technical List N°49),
- 8860-2004 or 8860-2010 (Technical List N°33), or
- 8860-2018 or 8860-2018-ABP (Technical List N°69)

Article 2- Flame-resistant clothing

- 2.1-** In circuit competitions, hill-climbs, special stages of rallies and selective sections of cross-country competitions entered on the International Sporting Calendar, all drivers and co-drivers must wear overalls as well as gloves (optional for co-drivers), long *underwear*, a *balaclava*, *socks and shoes homologated to the FIA 8856-2000 standard (Technical List N°27) or FIA 8856-2018 standard (Technical List No 74)*.
- 2.2-** Embroidery sewn directly onto the overalls shall be stitched onto the outermost layer only, for better heat insulation. Backing material of badges and thread used for affixing them to the overalls must be flameproof. The stitching of badges can go through all the layers, provided that the thread is flameproof and compliant with ISO 15025.
- 2.3-** Substances which may circulate in any cooling system worn by a driver are restricted to water, or air at atmospheric pressure. Water systems must not require the saturation of a garment in order to function.

Article 3- Frontal Head Restraint (FHR)

- 3.1-** The wearing in an international competition of any device intended to protect the head or neck and attached to the helmet is prohibited, unless the device has been homologated according to the FIA 8858 standard. Homologated FHR systems are listed in the FIA Technical List N° 29. The minimum reclined HANS collar angle shall be 60° from the horizontal.

Any padding used between the driver and the HANS® yoke must not be more than 15 mm thick when the driver is seated in the car fully equipped with the harness tightened. The padding must be covered by a flameproof material in conformity with the standard ISO 15025 and the padding must not be wider than 8 mm on each side of the HANS® yoke.



3.2- Conditions of use

FHR systems must be worn only with FIA-approved items according to the following chart:

Helmet	Tether system (tether, tether end fitting and helmet anchorage)
FIA 8860 (Technical List N° 33 & 69) FIA 8858 (Technical List N° 41) FIA 8859 (Technical List N° 49)	FIA 8858 (Technical List N° 29)

The FHR device must be worn in accordance with:

- a)- the “Guide and installation specification for HANS® devices in racing competition”, or
- b)- the “Guide and installation specification for Hybrid & Hybrid Pro devices in racing competition”.

Article 4- Frontal Head Restraint (FHR)

Drivers must be properly restrained in their seat by safety belts in conformity with the technical regulations for the vehicle concerned, at all times during a competition when it is mobile on a circuit, pit lane, special stage or competition course.

APPENDIX 6:

MOUNTING OF ON-BOARD CAMERAS INTERIOR / EXTERIOR

1- INTERIOR MOUNT

The mounting should be of a rigid type, placed in the centre behind the back of the seats.

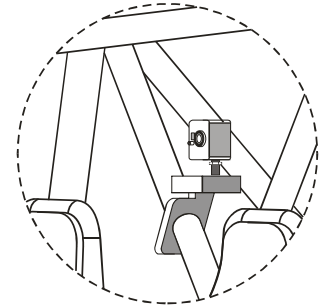
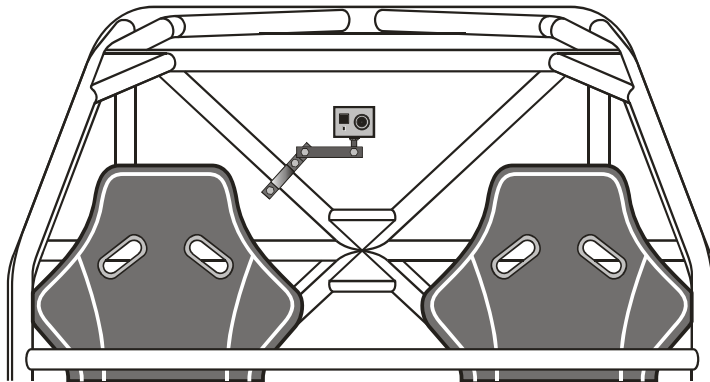

Handlebar Mount



For pencil type cameras, they can be mounted on the front rollbar windscreen pillar, the control unit should be fixed on the floor pan behind the seats. (Similar to battery fixation)

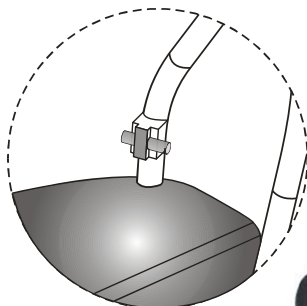

On front Rollbar

OR

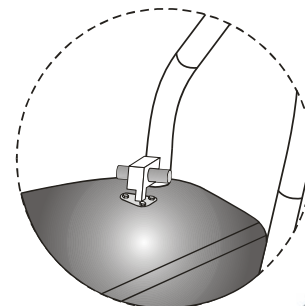

On dashboard



2- EXTERIOR MOUNT

A support bracket of 40mm. fixed by screws with a reinforcement plate of minimum 3mm thick and a surface of 120 cm² should be used

IMPORTANT: The reinforcement plate should be placed from inside the body work in order to reinforce the support area.

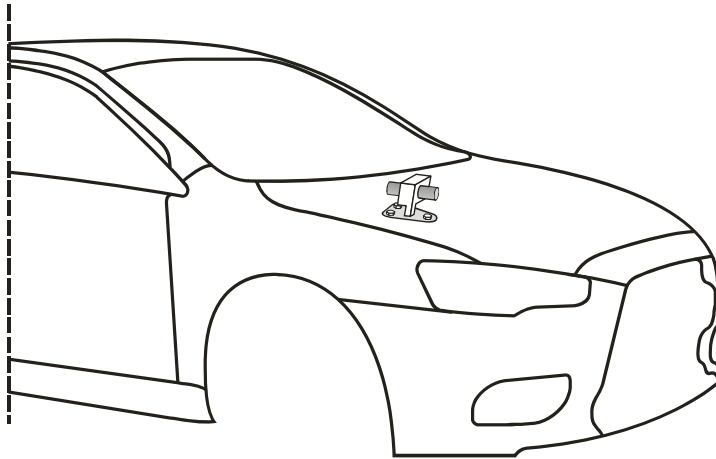

3- PROHIBITED MOUNTINGS

