

# 8<sup>th</sup> JEZZINE RALLY

June 8<sup>th</sup> – 9<sup>th</sup>, 2019



## SUPPLEMENTARY REGULATIONS



### Organised by

The Automobile and Touring Club of Lebanon

P.O. Box 115 - Jounieh / Lebanon

Tel.: +961-9-640220 / 640567 / 932020

Fax: +961-9-640579 / 934662

e-mail: [atcl@inco.com.lb](mailto:atcl@inco.com.lb)

web site: [www.atcl.org](http://www.atcl.org)

Facebook: ATCL Motorsports

## CONTENTS:

	<u>Page</u>
1. Introduction	3
2. Organisation and Description	3
3. Programme and Deadlines	5
4. Entries	7
5. Insurance	10
6. Advertising & Identification Numbers	11
7. Tyres	11
8. Fuel	12
9. Reconnaissance	14
10. Administrative Check	16
11. Scrutineering, Sealing and Marking	17
12. Other Procedures	19
13. Identification of Officials	21
14. Prizes	22
15. Final Checks and Protests	23
APPENDIX 1 Itinerary	24
APPENDIX 2 Reconnaissance schedule	27
APPENDIX 3 Name and photograph of CRO	28
APPENDIX 4 Advertising and Identification Numbers	29
APPENDIX 5 Extracts from FIA Appendix L	31
APPENDIX 6 Mounting of On-Board Cameras	33

# 1 - INTRODUCTION:

## 1.1 - Announcement

This rally will be run in compliance with the FIA International Sporting Code and its appendices, the 2019 FIA Regional Rally Sporting Regulations, the National Sporting Code which comply with the FIA regulations and these Supplementary Regulations.

Modifications, amendments and/or changes to these Supplementary Regulations will be announced only by numbered and dated bulletins (issued by the Organiser, the Clerk of the Course or the Stewards).

## 1.2 - Road surface

The rally will be run on **Tarmac**.

## 1.3 - Overall SS distance and total distance of the itinerary

SS distance: **111.33 kms.**

Total distance: **315.48 kms.**

# 2 - ORGANISATION AND DESCRIPTION

## 2.1 – National titles for which the rally counts:

- The 2019 Lebanese Rally Championship for Drivers.
- The 2019 Lebanese Rally Championship for Co-Drivers.
- The 2019 Lebanese Cup for RC2/N4 Rally Drivers.
- The 2019 Lebanese Cup for RC3 Rally Drivers.
- The 2019 Lebanese Cup for RC4 Rally Drivers.
- The 2019 Lebanese Cup for RC5 Rally Drivers.
- The 2019 Lebanese Cup for Junior Rally Drivers/Co-Drivers.
- The 2019 Ladies Cup for the Lebanese Championship.

## 2.2 - Visa numbers - ASN:

ASN visa No: **R/2/2019**

Issued on: **February 8<sup>th</sup>, 2019**

## 2.3 - Organiser's name, address and contact details (permanent office)

The Automobile and Touring Club of Lebanon  
Kaslik; Jounieh  
National Sporting Committee / Permanent Secretariat  
8th Jezzine Rally Office

P.O. Box 115 - Jounieh / Lebanon  
Tel.: +961-9-640220 / 640567 / 932020  
Fax: +961-9-640579 / 934662  
e-mail: [atcl@inco.com.lb](mailto:atcl@inco.com.lb)  
website: [www.atcl.org](http://www.atcl.org)  
Facebook: **ATCL Motorsports**

#### 2.4 - Organisation committee:

Chairman	Nicolas El Hindy
Members	Ziad Jamous Georges Ferzly Raffi Khederlarian Lian Tawtah

#### 2.5 - Stewards of the Meeting:

Chairman of the Panel	Nicolas el Hindy (Chairman) Gabriel Hayek Ramez Haddad
Secretary to the Stewards	Neveen Hachem

#### 2.6 - Observers and Delegates:

ASN Sporting Delegate	Gaby Kreiker
-----------------------	--------------

#### 2.7 - Senior Officials:

Clerk of the Course	Ziad Jamous
Deputy Clerk of the Course	Dr Guy Hokayem
Chief Safety Officer	Georges Ferzly
Scrutineers	Raffi Khederlarian (Chief) Georges Haddad Hovsep Aslanian Khalil Hashem Ardem Sarkissian Edgard Kfoury Anthony Bassil
Competitors' Relations Officer	Michel Schucry
Chief Medical Officer	Dr. Guy Hokayem
Media Relations Officer	Jalal Beaino
Tracking Monitoring Officer	Neeman Hatem
Judges of Fact:	All the named officials on this page.
Results Officer	Fady Eid
Secretary of the Rally	Joelle Daou

#### 2.8 - HQ location and contact details

The Rally HQ is located at:

**Jezzine Municipality**  
Jezzine; Lebanon  
E-mail: [atcl@inco.com.lb](mailto:atcl@inco.com.lb)  
Web site: [www.atcl.org](http://www.atcl.org)

#### 2.9 - Location of Holding Area and Parc Fermé:

Holding Area and Parc Ferme will be located at Jezzine Main Square.

## 2.10 - Location of Service park(s):

The Service Park is located at Jezzine Main Square.

## 3 - PROGRAMME AND DEADLINES: (IN CHRONOLOGICAL ORDER)

### Monday May 20<sup>th</sup> 2019

10:00hrs	Opening date for entries.	Rally Office A.T.C.L.; Jounieh
----------	---------------------------	-----------------------------------

### Monday June 3<sup>rd</sup> 2019

12:00hrs	Submittal of Fuel Purchase Form.	TOTAL Liban Ashrafieh; Beirut
15:00hrs	Closing date for entries.	Rally Office A.T.C.L.; Jounieh
15:00hrs	Closing date for co-driver details.	Rally Office A.T.C.L.; Jounieh
15:00hrs	Closing date for submitting all forms	Rally Office A.T.C.L.; Jounieh

### Tuesday June 4<sup>th</sup> 2019

10:00hrs	Publication of the Entry List on the official notice board.	Rally Office
11:00hrs	Publication of convocations to administrative checks and scrutineering.	Rally Office A.T.C.L.; Jounieh

### Thursday June 6<sup>th</sup> 2019

09:00hrs	Opening of media centre and media accreditation.	Rally Office A.T.C.L.; Jounieh
17:30 till 20:00hrs	Collection of material and documents. Issuing of Road Book	U-Stop Bosch Service Hazmieh
18:00 till 21:30hrs	Administrative Checks (Convocations will be carried out according to an individual time schedule).	U-Stop Bosch Service Hazmieh
18.30 till 22.00hrs	Scrutineering - sealing and marking (The administrative checks must be completed before the scrutineering of the cars. Convocations will be carried out according to an individual time schedule).	U-Stop Bosch Service Hazmieh
22:00hrs	First stewards' meeting	U-Stop Bosch Service



### Friday June 7th 2019

08:30hrs	Reconnaissance starts	
9:30hrs	Publication of Start List for Section 1 Leg 1, on the official notice board.	Rally Office A.T.C.L.; Jounieh
10:30hrs	Publication of the Ceremonial Start	Rally Office
18:30hrs	Reconnaissance ends.	A.T.C.L

### Saturday June 8<sup>th</sup>, 2019

14:30hrs	Opening of the Rally Headquarters.	Jezzine Municipality
15:30-16:30hrs	Cars entry to the Start Holding Area	Jezzine; Lebanon
17:00hrs	Rally Start – TC1 Section 1 – Leg 1	Jezzine Main Square Jezzine; Lebanon
19:00hrs	Finish Section 1	Parc Ferme Jezzine, Lebanon

### Sunday June 9<sup>th</sup>, 2019

07:00hrs	Start Section 2 – Leg 1	Parc Ferme Jezzine, Lebanon
17:00hrs	Finish Leg 1	Jezzine Main Square Jezzine; Lebanon
17:15hrs	Finish Ceremony and Prize-giving.	Jezzine Main Square Jezzine; Lebanon
17:45hrs	Final scrutineering.	Jezzine Main Square Jezzine; Lebanon
18:00hrs	Publication of the Provisional Final Classification.	Jezzine Main Square Jezzine; Lebanon
18:30hrs	Publication of the Official Final Classification.	Jezzine Main Square Jezzine; Lebanon

### Official Notice Board

- Tuesday May 20<sup>th</sup>, 2019 to Friday June 7<sup>th</sup> 2019  
**Rally Secretariat**  
The Automobile and Touring Club of Lebanon  
Kaslik; Jounieh  
National Sporting Committee Office
- Saturday and Sunday June 8<sup>th</sup> – 9<sup>th</sup>, 2019  
**Rally Headquarters**  
Jezzine Municipality  
Jezzine; South Lebanon

## 4 - ENTRIES

### 4.1 – Closing date for entries:

Monday June 3<sup>rd</sup>, 2019 at 15:00hrs

### 4.2 - Entry procedure:

Any person wishing to take part in the 8th Jezzine Rally must complete and send the entry form (including co-driver details) to the Rally Office (for address details please refer to Art. 2.3 of these Supplementary Regulations).

All entry forms must be signed by the entrant and each crew member prior to the start of testing and/or reconnaissance. Foreign competitors must hold an authorisation from their parent National Sporting Authority.

Entry forms will only be accepted if accompanied by:

- The total amount of the entry fees.
- A deposit against the tracking devices.
- Photocopy of the first page of the homologation book for the car.
- Photocopy of the entrant / competitor licence.
- Photocopies of crew members' competitions licences.
- Photocopies of crew members' valid driving licences.
- A letter from the owner of the car and/or a power of attorney (if the car is not the property of the crew members).

### 4.3 - Number of entrants accepted and classes:

The maximum number of entries is 40 cars. If more than 40 entries are received, the Organisers reserve the right to decide which entries (among the non-priority drivers) to be accepted.

### 4.4 – Classes and Groups:

The eligible vehicles to participate in rallies are as follows:

#### a) Homologated Vehicles

All vehicles classes described in Article 4.1 of the 2019 FIA Regional Rallies Championships Sporting Regulations, excluding RGT class cars. The concerned cars must be in conformity with Appendix J of the F.I.A International Sporting Code for the running year.

#### • Additional provisions:

- Cars homologated as Kit cars, where the capacity is between 1400 and 1600cc, may be accepted if they also comply with Article 255-6.2 “Weight” of Appendix J.
- Two-wheel drive cars equipped with a supercharged diesel engine with a nominal cylinder capacity of less than 2000cc are accepted in Groups A and N.
- For drivers entered with a Super 2000-Rally car complying with 2013 Appendix J, Art. 255A, it will be possible to use lapsed errata without any penalty.
- For Super 1600 homologated cars, it will be possible to use lapsed errata without any penalty.
- An FIA technical passport is mandatory for S2000, R5, and Super 1600.

- The complete original FIA homologation form and other necessary certifications must always be available.
- b) Vehicles with Expired Homologations and ASN Approved Cars:**
  - In Compliance with Article 2.7.1.c of the 2019 FIA International Sporting Code, cars whose homologations have expired and, still accepted by the FIA, up to a maximum of eight years before the beginning of the current year, *i.e. Jan 1<sup>st</sup> 2011 up to Dec 31<sup>st</sup> 2018.*
  - **ASN Approved Cars**, in Compliance with the 2019 National Sporting Code, Appendix C, Article 1.1.b.ii and, Article 4.3.6 of the 2019 FIA Regional Rallies Championship Sporting Regulations whose homologations have expired between nine and ten years before the beginning of the current year, *i.e. Jan 1<sup>st</sup> 2009 up to Dec 31<sup>st</sup> 2010*, excluding RGT cars, are permitted to participate in the 8<sup>th</sup> Jezzine Rally. **These cars must, however, comply with the safety requirements as stipulated in Appendix J, Art. 253.**
  - It is **MANDATORY** for these vehicles within this category to be in conformity with their expired homologation forms and, in a sound condition to participate, at the discretion of the scrutineers. These cars may only be accepted for participation if the correct, though expired, homologation papers are produced at documentation and at scrutineering.
  - The size of turbo restrictors used on turbo-equipped cars must be in conformity with Appendix C of the 2019 National Sporting Code.
  - The minimum weights are those currently valid.
  - FIA and Lebanese ASN seeded drivers are not permitted to drive such cars in the 8<sup>th</sup> Jezzine Rally.

#### 4.5 - PROMOTION classification

There will be a PROMOTION classification for the Lebanese competitors with the following conditions:

- a) To hold the Lebanese nationality and competition licence.
- b) Not to be F.I.A. priority driver.
- c) Not to be MERC priority driver.
- d) Not to be an A.S.N. priority driver.
- e) The car must be the property of one of the crew members and not the property of any dealer or manufacturer.
- f) Have not been classified among the first 3 during the past two years at the Rally of Lebanon.

A list of PROMOTION classification will be issued at the same time along with the entry list.

#### 4.6 - Entry fees and entry packages:

##### 4.6.1 The entry fees are as follows:

- a) With the optional advertising proposed by the Organisers
 

* For Private Entrant	USD750. - U.S. \$
* For Legal Entrant	USD1,500. - U.S. \$
- b) Without the optional advertising proposed by the Organisers
 

* For Private Entrant	USD1,500. - U.S. \$
* For Legal Entrant	USD3,000. - U.S. \$



**Private Entrant:** For an entry for the 8th Jezzine Rally to be considered as a private entry, the following conditions must be complied with:

- a) The car entered must be personal property of one of the crew members and the car licence must be in his/her name.

If the car is not the property of one of the crew members, a letter of authorisation from the owner of the car and/or a power of attorney approving the use of the car should be accompanied along with the entry form.

Letters of authorisation and/or powers of attorney dated more than three months before the date of the rally will not be considered.

- b) The entry form must be made in the name of one of the crew members, not in the name of a sponsor or any commercial organisation.
- c) The entrant's competition licence must be in the name of one of the crew members.

Unless all of the above mentioned conditions are met, the entry will not be considered as a private entry and the appropriate entry fees will be liable for payment.

**Legal Entrant:** The competing car entered by a team, a manufacturer, a company or other legal entity (with legal entrants / competitors licence).

**4.6.2** The entry fees specified in Article 4.6.1 (aforementioned) include:

Item	Private Entrants	Legal Entrant
Driver Passes	2	2
Service Personnel Passes	6	8
"Service" plates	1	2
Road Book	1	1

Should additional material deem necessary; it can be ordered from the rally secretariat by using the "Additional materials order form".

**4.6.3** The change of one crew member will be subject to article 21.4 of the 2019 FIA Regional Rally Sporting Regulations. However, an additional fee of 50.- U.S. \$ will be imposed in case of changing a crew member.

#### 4.7 - Payment details:

Entry Fees can be remitted to the Organiser's Bank Account:

Bank: BLOM Bank (Banque du Liban et d'Outre-Mer)

Bank address: Kaslik Branch

Account N°: 023 - 02(300) 067 36 21 - 1 - 6(44037) and to the order of  
The Automobile and Touring Club of Lebanon

IBAN: LB21 0014 0000 2302 3000 6736 2116

SWIFT CODE: BLOMLBBX

Any bank charges incurred by a swift transfer must be charged to the sender's account.

Entry fees paid by bank transfer shall simultaneously be advised to the Rally Office by fax and/or e-mail to ensure that payment is received in full prior to the close of entries.

#### 4.8 - Refunds:

Entry fees will be refunded in full:

- a) To candidates whose entry has not been accepted.
- b) In case the 8th Jezzine Rally does not take place.
- c) Organisers may refund up to 30% of the entry fee to those competitors who, for reasons of “force majeure” (duly certified by their ASN), were unable to start in the rally.

## 5 - INSURANCE

- a) The insurance guaranties the competitors for civil liability towards third parties for a maximum of USD 100.000 as total liability for this event. The insurance cover will come into effect from the start until the end of the rally or at the moment of permanent retirement, disqualification or exclusion.
- b) Beside the insurance provided by the organisers, it is compulsory for all entrants / competitors to have their rally vehicle covered by a third party liability, during their stay in Lebanon.  
A copy of the insurance certificate should be presented along with other documents upon administrative checks (refer here under to Art. 10.3 of these Supplementary Regulations).
- c) It is mandatory that all foreign crew members have Motor Sport Personal Accident Insurance valid for Lebanon, or a Prise en Charge issued by the crew members parent ASN. Otherwise, the Organiser will provide such insurance for a premium of 250. - U.S. \$.
- d) The service, management vehicles and reconnaissance vehicles including those bearing special plates issued by the Organisers may never be considered as official participants in the rally. They are therefore not covered by the insurance policy of the rally and will remain the sole responsibility of their owners.
- e) Damages to rally cars as well as liability of a crew member towards the other crew member or car are not covered by the insurance provided by the Organisers.
- f) **Accident Reporting:**  
In compliance with Article 40.4 of the 2019 FIA Regional Rally Sporting Regulations, “if a crew is involved in an accident in which a member of the public sustains physical injury, the car must stop immediately, and the procedure as laid down in article 40.3.1 must be followed”. All crews stopped by this procedure will be allocated a time according to Article 39 of the 2019 FIA Regional Rally Sporting Regulations.

However, if the driver fails to observe this rule, the stewards of the meeting may impose on the responsible crew a penalty which may go as far as disqualification.

Moreover, it is compulsory for the competitor or his representative to notify the Clerk of the Course and/or the Competitor's Relations Officer(s) in writing within 4 hours with the full details including the names and addresses of those involved and witnesses if any.

## 6 - ADVERTISING AND IDENTIFICATION

### 6.1 - Advertising:

- a) The advertising of tobacco products is allowed on the condition of mentioning the required warnings recommended by the Lebanese government according to the Lebanese law at the time of going to print.
- b) Advertising regarding alcoholic beverages is permitted.
- c) The advertising of political, religious and/or social material is strictly forbidden.
- d) Competition numbers, rally plates and advertising shall be affixed on the car before scrutineering. These must be visible through the whole duration of the rally under the pain of penalty (Article 6.2-b of these Supplementary Regulations.).
- e) Spaces set by the Organisers (refer to Appendix 4 of this Supplementary Regulation) must be reserved on the car, if the entrant has accepted the Organiser's optional advertising, unless he pays the Entry Fees without Optional Advertising proposed by the Organisers in accordance with Article 4.6.1-b of this Supplementary Regulation.

### 6.2 - Identification numbers:

- a) The rally plates and numbers will be provided by the Organisers in compliance with the FIA Regional Rally Sporting Regulations. These numbers must be affixed as specified in Appendix 4.
- b) The missing and/or covering of a rally plate will result in a cash penalty of 100. - U.S. \$
- c) Service and/or auxiliary vehicle plates shall be affixed on the inside of the windscreen in the top right hand corner of the vehicle.

## 7 – TYRES

- a) All tyres must comply with Article 60 of the 2019 FIA Regional Rally Sporting Regulations read in conjunction with Appendix V, Article A - Tarmac Tyre Regulations.

The list of eligible asphalt tyres for FIA rallies, which are the only tyres allowed, can be found on the FIA website under the following link:

<https://www.fia.com/regulations/category/117>

- b) **The use of slick tyres is prohibited.**

- c) In accordance with Article 60.1.6 of the 2019 FIA Regional Rally Sporting Regulations, the use of any device for maintaining the full performance of the tyre with an internal pressure equal to or less than atmospheric pressure is forbidden. The interior of the tyre (the space between the rim and the internal part of the tyre) must be filled only with air.
- d) In accordance with Article 60.13 of the 2019 FIA Regional Rally Sporting Regulations, all tyres used in this rally must be readily available commercially.
- e) Tyre changes may only be carried out in authorised zones.
- f) Tyre marking zones will be organised after the exit TC of the Service Park.
- g) Any breach of the tyre regulations will be submitted to the Stewards and may result in a penalty, which may go as far as the exclusion of the crew by the Stewards.

## 8 – FUEL

### 8.1 Fuel supply

**8.1.1** - Throughout the 8th Jezzine Rally, all entered cars shall **SOLELY** use fuel supplied by “TOTAL Liban”, which meets the technical requirements of FIA Appendix J.

**8.1.2** - Two types of petrol are available:

- a) ELF TURBO REF (50 litre canisters), sold at the price of \$ **7.70** /litre VAT included.
- b) TOTAL EFFIMAX 98 octane, sold at current price of the market at delivery time, VAT included.

**8.1.3** - “TOTAL Liban” will supply the fuel needed for the adjustments, against request and upon payment.

**8.1.4** - Closing date for ordering fuel

- a) Each competitor must fill in and submit the special Fuel Purchase Form requesting the quantity of fuel needed for the rally and send it, no later than 12:00hrs on Monday, June 3<sup>rd</sup>, 2019, to:

TOTAL Liban  
Tilal Beirut Bldg., 2<sup>nd</sup> floor  
Rue Ashrafieh  
Ashrafieh; Beirut; Lebanon  
P.O. Box 11-3636 - Beirut / Lebanon  
Tel.: +961-1-212250 Fax: +961-1-216014  
e-mail: [michel.hajjar@total-liban.com](mailto:michel.hajjar@total-liban.com)

- b) Payment details:  
Payments can be remitted to the supplier’s bank account:

Bank: Bank Audi  
Bank address: Centre SOFIL, Ashrafieh Branch  
IBAN: LB86 0056 0002 0206 7421 0020 0936  
Devise: USD  
SWIFT CODE: AUDBLBBX

Any bank charges incurred by a swift transfer must be charged to the sender's account.

Moreover, a copy of fuel purchase invoice should be presented along with other documents in the administrative checks.

In case of failure to collect part of the fuel, the purchaser will be refunded with the corresponding amount of the remaining fuel in sealed canisters ONLY for TURBO REF Type, within 15 days after the end of the rally.

### 8.1.5 Fuel dispense

The fuel will be dispensed to the competitor or his representative (duly assigned in writing) at the refuelling zone – as indicated in the Road-Book - subject to presenting the voucher given by “TOTAL Liban” and in compliance with the schedule filled on the Fuel Purchase Order and mutually agreed upon between “TOTAL Liban” and the purchaser.

It is the competitors' responsibility to fill the appropriate form given by TOTAL Liban regarding the quantity to be dispensed at each of the refuelling zones in the rally.

## 8.2 General provisions

- a) The fuel tank capacity should meet and cover the time and distance table of the rally, *i.e. the rally itinerary*.
- b) Except as detailed under Article 50 and in accordance with Article 58.1 of the 2019 FIA Regional Rally Sporting Regulations, competitors may only refuel in the refuel zones designated by the Organisers in the road-book. Other activities inside the refuelling zone are strictly prohibited.  
Any breach of these regulations will be reported to the Stewards who may apply penalties at their discretion which may go as far as the disqualification of the crew.
- c) Refuelling procedure (Article 58 of the 2019 FIA Regional Rally Sporting Regulations):
  - Only actions inside a refuelling zone directly involved in the refuelling of the competing vehicle are permitted.
  - In all refuelling zones, a 5 kph speed limit will apply.
  - The responsibility for refuelling is incumbent on the competitor alone.
  - It is **MANDATORY** for the relevant personnel for the refuelling to be wearing clothing which will provide adequate protection against fire.
  - Engines must be switched off throughout the refuelling operation.

- It is recommended that the crew remains outside the car during refuelling; however, should they remain inside, their safety belts must be unfastened.
  - Solely for the purpose of assisting with the refuelling procedure of their car, two team members of each crew may access this zone.
  - A car may be pushed out of the zone by the crew, officials and/or the two team members without incurring a penalty.
- d) The organisers may make provisions for additional refuelling zones. However, these additional zones shall only be positioned along the itinerary. Except for refuelling rally vehicles, any other kind of servicing is strictly prohibited.

Any breach of the fuel and/or refuelling regulations will be submitted to the Stewards and may result in a penalty, at their discretion, which may go as far as the disqualification.

## 9 - RECONNAISSANCE

### 9.1 - Procedure for registration:

- a) Reconnaissance Cars must be in conformity with Article 25.1 of the 2019 FIA Regional Rally Sporting Regulations, and must be covered by insurance as required by the traffic laws of Lebanon, no responsibility being imputable to the organisers.
- b) When registering for reconnaissance, one of the crew members must be present to sign an indemnity and register the details of the reconnaissance car (spare recce car, if any), mobile telephone number and contact details of the place of residence.
- c) The Reconnaissance Registration Form can be collected from the Rally Secretariat or downloaded from the A.T.C.L. official website. This form should be filled and sent to the Rally Secretariat before commencing the reconnaissance.

### 9.2 – Reconnaissance Schedule:

The road book will be issued on Thursday, June 6<sup>th</sup>, 2019, and will be distributed between 17:30 and 20:00hrs at U-STOP Bosch service Hazmieh.

The Reconnaissance Schedule starts on Friday, June 7<sup>th</sup>, 2019, at 8:30hrs time and ends on Friday, June 7<sup>th</sup>, 2019, at 18:30hrs. No Reconnaissance allowed outside these mentioned dates and times.

**Any competitor found in breach of this rule, will be reported to the stewards who may apply penalties at their discretion.**

**Jezzine Super Special Stage Reconnaissance will be available on Friday 7<sup>th</sup> June from 16:00hrs till 16:30hrs ONLY and under the supervision of Jezzine Municipality police.**

### 9.3 - Specific and national restrictions – speed limit:

- a) Reconnaissance outside the aforementioned Reconnaissance Schedule, Article 9.2 of this Supplementary Regulation, as from the dates of publication of the itinerary on the A.T.C.L official website, to the date and time of the Start of the Rally is **PROHIBITED**. The presence of any driver or co-driver, or any other team member who has entered or intends to enter in the 8th Jezzine Rally, outside the Reconnaissance Schedule, on any part of a special stage to be used in the rally, in any way whatsoever, is considered as **illegal reconnaissance**, and a breach of this supplementary regulations; he or she will be reported to the stewards who may apply penalties at their discretion.
- b) Crews will only be permitted to enter and leave special stages through the start and finish controls shown in the Road Book and may not, under any circumstances, drive in a direction opposite to that of the rally.
- c) **Maximum speed limit of 50 km/h during reconnaissance is imposed on all special stages, 30 km/h inside populated villages**, unless another speed limit is indicated by traffic signs. In compliance with Article 20.2.2 of the 2019 FIA Regional Rally Sporting Regulations, speeding during reconnaissance will incur a fine applied by the clerk of the course as follows:
- Per km per hour over the speed limit: € 25
- The amount of this fine will be unaltered by any fine imposed by the police.
- The fine will be doubled in case of a second offence committed during reconnaissance in the same rally.
- Other traffic infringements during reconnaissance will incur a fine applied by the Stewards.
- d) **All cars must have their headlights on at all times whilst travelling on the special stages.**
- e) Any breach of the reconnaissance regulations, of the 2019 FIA Regional Rally Sporting Regulations and these Supplementary Regulations, will result in a penalty, which may go as far as disqualification, at the discretion of the Stewards.

#### 9.4 - Fitment of speed control checking devices:

It is emphasized that reconnaissance is not a practice run. The competitors must drive in a manner that does not endanger or cause inconvenience to traffic or people living within and near the stages. During reconnaissance, the traffic laws of Lebanon must be strictly complied with as well as the safety and rights of ways of other road users should be respected.

The police may check the speed on the road sections and the special stages using speed check equipment.

#### 9.5 – Compulsory Drivers Briefing

A briefing will be given to the competing crews by the clerk of the course, his deputy and/or by an appointed official.

The briefing will target specific points of the rally and of these Supplementary Regulations relating to the organisation of the event, give any clarification

concerning the interpretation of the regulations, and to remind the drivers of the safety provisions, either specific and/or general.

The participation of both or one of the crew members is compulsory.

Team managers may attend the meeting.

The briefing will be held at 19.30hrs on Friday, June 7<sup>th</sup>, 2019 at:

**L'Iris Flower Hotel (Jezzine)**

It is mandatory that a minimum one member of each crew to attend this briefing, from the starting the time set here-above. A fine of €200 shall be applied on the crew who breaches this regulation.

**9.6 - Comment on tyres:**

Complying with Article 25.2.a of the 2019 FIA Regional Rally Sporting Regulations, road-homologated series production tyres for asphalt are to be used for reconnaissance.

Any breach of the reconnaissance regulations, will result in a penalty at the discretion of the Stewards, which may go as far as exclusion. Furthermore, the Stewards may report the competitors concerned to the CSN for possible further sanctions.

## 10 - ADMINISTRATIVE CHECKS

**10.1 - Location:**

Administrative checks will take place on Thursday, June 6<sup>th</sup> 2019 at:

**U-Stop Bosch Service**  
Hazmieh

Address: Sayyad Roundabout hadath road facing plaza

Both crew members have to attend the administrative check. However, Legal Entrants as well as FIA, MERC and ASN priority drivers may appoint a representative and/or a team manager (duly assigned in writing) for their entries.

**10.2 - Times / schedule:**

From 18:00hrs till 21:30hrs, according to an individual time schedule given later in a bulletin or a communication and posted on the official notice board at The Automobile and Touring Club of Lebanon; Jounieh - Lebanon.

Any crew reporting outside their time limits for Administrative Checks will be penalized 15. - U.S. \$ per minute to maximum of 15 minutes. Thereafter, they will be reported to the Stewards who may apply penalties at their discretion.

**10.3 - Documents to be presented:**

The following items will be checked at Administrative Checks:

- Entrants' licence (if any).
- Drivers' and Co-drivers' competition licences.
- Valid drivers' and Co-drivers' driving licences.
- Rally car documents and registration papers etc...

If the car is not the property of one of the crew members, a letter of authorisation from the owner of the car and/or a power of attorney



approving the use of the car should be accompanied along with the entry form.

Letters of authorisation and/or powers of attorney dated more than three months before the date of the rally will not be considered.

- Insurance policy covering the rally vehicle (refer to Art. 5.b of these Supplementary Regulations.
- Motor Sport Personal Accident Insurance (Refer to Art. 5.c of these Supplementary Regulations.
- Copy of fuel purchase invoice.
- Correctness and completion of all information given on the entry form.
- Authorisation for the drivers by their ASN to take part in the rally should be presented.
- Drivers' and co-drivers' medical certificates of aptitude valid for the current year as given to them by their parent ASN. These certificates must be in accordance with the ISC Appendix L, Chapter II, Article 1.8.

Competitors are required to hold a signed Administrative Clearance Form prior to Scrutineering.

## 11 - SCRUTINEERING, SEALING AND MARKING

The Administrative Check must be completed prior to Scrutineering. Competitors are required to present their signed Administrative Clearance Form prior entering the Scrutineering venue.

### 11.1 - Location:

Scrutineering, Sealing and Marking will take place on Thursday, June 6<sup>th</sup>, 2019 at:

**U-Stop Bosch Service**  
Hazmieh

Address: Sayyad Roundabout hadath road facing plaza

Both crew members have to attend the Scrutineering. However, Legal Entrants as well as FIA, MERC and ASN priority drivers may appoint a representative and/or a team manager (duly assigned in writing) for their entries.

### Times / schedule:

From 18:30hrs till 22:00hrs, according to an individual time schedule given later in a bulletin or a communication and posted on the official notice board at the Automobile and Touring Club of Lebanon; Jounieh - Lebanon.

Any crew reporting outside their time limits for Scrutineering will be penalized 15. - U.S. \$ per minute to maximum of 15 minutes. Thereafter, they will be reported to the Stewards who may apply penalties at their discretion.

### 11.2 - Windows/Nets:

In compliance with the traffic law of Lebanon, **the use of silvered or tinted film is NOT AUTHORISED** on the side as well as the rear windows.

However, and in compliance with Appendix J, Article 253.11, the use of transparent and colourless anti-shatter films on the side windows and the glass sunroof is mandatory.

### 11.3 - Driver's safety equipment:

- The control of drivers' helmets and equipment as well as the head restraint (FHR device) will take place at the scrutineering. The helmets must meet one of the standards listed in technical list No. 25 of Appendix J. Each helmet used by the crew will have to be identified and marked during the scrutineering before start. This marking may be checked on the start of each special stage.

Drivers' and co-drivers' overalls as well as gloves (optional for co-drivers), long underwear, a balaclava, socks and shoes should be homologated to FIA 8856-2000 standard.

- In compliance with ISC Appendix L, Chapter III, Article 3, the wearing of an FIA approved Frontal Head Restraint (FHR), homologated according to the FIA 8858 standard, on special stages is MANDATORY for all drivers and co-drivers. Homologated FHR systems are listed in the FIA Technical List N° 29.
- In compliance with Appendix L, Chapter III, Article 2, the wearing of long underwear homologated to the FIA 8856-2000 standard on special stages is MANDATORY for all drivers and co-drivers. (Technical List N°27).
- Infringements are subject to the penalty of refusal to take the start.
- In compliance with ISC Appendix J, Article 253.8.3.5, where the occupants' bodies could come into contact with the safety cage, flame retardant protective padding must be provided for protection. All tubes of the cage and all roof reinforcements must be fitted with paddings in compliance with FIA standard 8857-2001 type A; refer to *Technical List No. 23*. Each padding must be fixed in such a way that it is not moveable from the tube.

### 11.4 - Scrutineering requirements:

- Cars must be presented to the scrutineers with the competition numbers, rally plates and optional advertising affixed on the car before entering the Scrutineering venue. Failing to comply with this rule is subject to a cash penalty of 100. - U.S. \$ (Article 6.2.b of these Supplementary Regulations).
- In accordance with Article 26.1 of the 2019 FIA Regional Rally Sporting Regulations **the presentation of the car's complete original FIA homologation form in scrutineering is compulsory**. Any breach of these regulations will be reported to the Stewards who may apply penalties at their discretion.
- In accordance with Appendix J, Article 253.6, two belt cutters must be carried on board at all times. They must be easily accessible for the driver and co-driver when seated with their harnesses fastened.

- An authentic copy of the homologation document or certificate, of the roll cage approved by the ASN and signed by qualified technicians representing the manufacturer, must be presented to the event's scrutineers
- **In accordance with Appendix J, Article 252-3.6, “all cars used in Rallies ..., the noise level on the open road must not exceed 103 dB(A) for an engine rotation speed of 3500 rpm for petrol engines”.**
- In accordance with Article 40.2 of the 2019 FIA Regional Rally Sporting Regulations, each competing car shall carry a red “SOS” sign and on the reverse a green “OK” sign measuring at least 42 cm x 29.7 cm (A3).
- In accordance with Appendix A, Chapter X, Article 5 of the 2019 National Sporting Code, all Competitors, teams and entrants who wish to carry on-board cameras, in-car videos and/or film cameras must have the prior agreement of the Organisers beforehand. **However, it is MANDATORY to provide the Organisers and/or the Clerk of the Course with a copy of the complete unedited recordings upon requisition with no delay.** Authorised cameras will be identified by an adhesive decal and must be mounted in/on the car at the time of scrutineering. The mounting of on-board cameras (Interior/Exterior) to be in compliance with Appendix 7 of this Supplementary Regulations.  
The On-Board Camera Application Form can be collected from the Rally Secretariat or downloaded from the ATCL official website. This form should be filled and sent to the Rally Secretariat by **Monday June 3<sup>rd</sup>, 2019 at the latest.**  
Failing to observe this rule will be subject to a penalty at the discretion of the Stewards of the Meeting.

## 12 – OTHER PROCEDURES

- 12.1** – A deposit of **\$300** for the tracking devices to be submitted by the crew along with the Entry Fees; this deposit shall be refunded if the tracking devices are returned in sound conditions with a deadline of one week starting from time of the end of the rally. No refund shall be made beyond this set deadline.
- 12.2** - In accordance to Chapter X, Article 2, of the 2019 National Sporting Code that complies with Article 2.3.6.a.i of the 2019 FIA International Sporting Code, foreign licence- holders Competitors and Drivers are eligible to score points in the classification of the 8<sup>th</sup> Jezzine Rally that forms part of the Lebanese Rally Championship. The allocation of points in the ranking of the said championship, will take the Competitors and Drivers who are foreign licence- holders into account.

### 12.3 - Official start:

The start of the rally (TC 0) will take place at Jezzine followed by **Jezzine Super Special Stage** on Saturday, June 8th, 2019 at 17:00hrs in **Reverse Order**.

Competing cars and crews must assemble in the Start Holding Area between 15:30 and 16:30hrs.

Competitors reporting late to the start area will be penalized 15.- U.S. \$ per minute to a maximum of 15 minutes. Thereafter, Article 44.2 of the 2019 FIA Regional Rally Championships Sporting Regulations will apply.

#### 12.4 - Finish procedure:

The rally will conclude at the Finish Podium situated in Jezzine Main Square on Sunday, June 9<sup>th</sup>, 2019 at 17:15hrs. Competitors shall follow the Officials directions to the finish ramp, directly followed by the final Parc Fermé.

After clearing the finish ramp, the crews shall drive their cars, as instructed by the officials to the final Parc Fermé and/or scrutineering.

However, each crew may nominate a representative, duly assigned by writing, to take delivery of the car out of the final Parc Fermé. In the event that the car is not driveable this shall be reported to the Clerk of the Course and/or the Competitors' Relations Officer; the crew is solely responsible to arrange transport by a recovery vehicle on his own cost and in a timely manner.

#### 12.5 - Early check-in at the end of a day:

Crews are authorised to check in early without incurring a penalty at:

TC 10A

End of Leg 1/FINISH PODIUM

#### 12.6 - Special procedures / activities:

##### 12.6.a - Starting system:

The timekeeping in the special stages will be carried out to the 1/10<sup>th</sup> of a second.

The start of the special stages will be carried out by an electronic countdown system, placed on the left hand side of the road, between 2 and 5 meters ahead of the starting line, counting down by seconds and clearly visible to the crew from the start position.

This system is electronically coupled to a start line detection device that records any situation where a car leaves the start line ahead of the correct signal. This system may also be synchronized with a starting lights system of which the description and regulations will be included if appropriate in a bulletin.

Should the above starting light panel fail to function; the start will be given in accordance to Article 37.3 of the 2019 FIA Regional Rally Sporting Regulations.

##### 12.6.b - Starting order and interval:

- a) The starting order will be determined as follows:
  - FIA priority drivers
  - MERC priority drivers
  - Lebanese ASN priority drivers - Rallies
  - Other drivers
- b) All drivers will have an interval of one minute (**1min.**) between their start times.

##### 12.6.c - Time card change during the rally:

The Time Cards will be issued at the following time controls:

Section 1	TC 1	Start Section 1 / Leg 1
Section 2	TC 1B	Parc ferme OUT,
Section 3	TC 4B	Regrouping OUT
Section 4	TC 7B	Regrouping OUT

When retiring, the crew are obliged to hand their time card either to the next time control or otherwise to the Sweeper car.

### 12.7 - Official Time:

The official time throughout the entire rally will be based on GPS time (UTC +3 hours).

A display of the “Official Time” will be located at the event headquarters as well as on the starting podium.

### 12.8 – Excessive speed during the rally:

In compliance with Article 20.3.4 of the 2019 FIA Regional Rally Sporting Regulations, speeding during the rally will incur a fine applied by the clerk of the course as follows:

- € 25 per km per hour over the speed limit.

The amount of this fine will be unaltered by any fine imposed by the police.

## 13 - IDENTIFICATION OF OFFICIALS

The post chiefs and other officials will be identified as follows:

Senior Rally Officials	White shirts with their names in dark blue letters on their left.
Competitors' Relations Officers	Pink shirts with “C.R.O.” in large white letters weaved on their back.
Headquarters staff	Light grey shirts.
Media staff	Light yellow shirts.
Stages Commanders	Blue shirts bearing the A.T.C.L logo on it.
Stages Safety Officers	Navy blue shirts with “SAFETY” weaved on their back.
Stages Time Control Officers	Yellow tabards with “TEAM LEADER” in blue.
Special Stages posts chiefs	Yellow tabards with “TEAM LEADER” in blue.
Stages Doctors	Bright red tabards with “DOCTOR” in black.
Safety Marshals	Bright yellow tabards with “SAFETY” in grey.
Intermediary and Radio Points	Bright yellow tabards with blue radio point symbol.
Red flag marshals	Bright orange tabards with black radio point symbol.
Special Stages Marshals	Blue tabards with “MARSHALS” in white.

## 14 - PRIZES

### 14.1 - Prize-giving:

- The prize giving shall take place on the podium at the finish ramp situated in the Jezzine Main Square on Sunday, June 9<sup>th</sup>, 2019 at 17:15hrs.
- Competitors that are not personally present at the prize giving ceremony will lose their right to the prizes that are theirs. Nevertheless, the classification and attribution of the other prizes won't be modified.

### 14.2 - Prizes:

List of prizes and cups:

- General Classification:

First	2 Trophies.
Second	2 Trophies.
Third	2 Trophies.
- Class RC2/N4 Cup 2 Trophies (1<sup>st</sup> crew).
- Class RC3 Cup 2 Trophies (1<sup>st</sup> crew).
- Class RC4 Cup 2 Trophies (1<sup>st</sup> crew).
- Class RC5 Cup 2 Trophies (1<sup>st</sup> crew).
- Promotion Classification: 2 Trophies (1<sup>st</sup> in Promotion Classification, as per these Supplementary Regulations, Article 4.3.4).
- Junior Drivers/Co-Drivers Cup 2 trophies, 1<sup>st</sup> junior crew in the general classification.
- Ladies Cup: 2 Trophies, 1<sup>st</sup> Female Crew.
- All finishers: 2 Medals.

The Junior Drivers/Co-Drivers Cup will be awarded to the first junior driver and co-driver in the general classification registered for the 8th Jezzine Rally. In compliance with Article 12, Appendix A of the 2019 National Sporting Code to qualify for this cup, the following conditions will apply:

- The Driver/Co-Driver must have his/her 26<sup>th</sup> birthday after the end of the current year.
- The Driver/Co-Driver must be driving a 2WD cars of class RC3, RC4 and RC5.
- The driver and co-driver may not necessarily be members of the same crew.

## 15 - FINAL CHECKS AND PROTESTS

### 15.1 - Final checks:

The final scrutineering will take place at the Jezzine Main Square on Sunday, June 9<sup>th</sup>, 2019 at 17:45hrs.

Cars subject to final checks (decision by the Stewards) must have one representative for the entrant as well as mechanics, in case of dismantling, present at the final check.

### 15.2 - Protest and Protest Deposits:

- a) Accompanied with the protest deposit, all protests must be lodged in writing and handed to the clerk of the course within the time set in Article 13 of the 2019 International Sporting Code.
- b) In compliance with Article 55 of the 2019 FIA Regional Rally Sporting Regulations, each protest deposit is set at € **1,000**, which shall not be returned if the protest is judged unfounded.

If the protest requires the dismantling and the re-assembly of different part of a car, the claimant must pay an additional deposit:

- i. If the protest involves a clearly defined part of the car (engine, transmission, steering, braking system, electrical installation, bodywork, etc.): **USD2,000** per each.
  - ii. Protests involving the whole vehicle are inadmissible.
- c) The expenses incurred in the work and in the transport of the vehicle shall be borne by the claimant if the protest is unfounded, or by the competitor against whom the protest is lodged if the claim is founded.
  - d) If the claim is unfounded, and if the expenses incurred by the protest (scrutineering, transport etc.) are higher than the guarantee deposit, the difference shall be borne by the claimant.

Conversely, if the expenses are less, the difference shall be returned to him.

### 15.3 - Appeal deposit:

- a) The sum of the National appeal deposit (ASN): **USD 4000**

## APPENDIX 1: ITINERARY OF THE RALLY

### 8<sup>th</sup> JEZZINE RALLY

Version (1), 22/05/2019

Saturday, June 8<sup>th</sup>, 2019

LEG 1						
TC	LOCATION	SS dist.	Liaison dist.	Total dist.	Target time	First due
	Start Leg 1 – Jezzine square	-	-	-	-	-
1	Jezzine	-	-	-	00:20	17:00
SS1	<b>JEZZINE 1</b>	<b>1.20</b>	-	-	-	<b>17:03</b>
1A	Regrouping / Technical Zone IN	-	0.23	1.43	00:4	17:07
<b>OVERNIGHT PARC FERME</b>						
<b>Saturday Totals</b>		<b>1.20</b>	<b>0.23</b>	<b>1.43</b>		

Section 1

Saturday, June 8<sup>th</sup>, 2019: Dawn: 03:45hrs.  
Sunrise: 05:28hrs.  
Sunset: 19:47hrs.



RE-START LEG 1				Sunday, June 9 <sup>th</sup> , 2019		
TC	LOCATION	SS dist.	Liaison dist.	Total dist.	Target time	First due
<b>Re-Start Leg 1 – Section 2 (Jezzine Main Square)</b>						
1B	Parc Fermé OUT	-	-	-	-	07:01
1C	Service IN	-	0.50	0.50	00:01	07:02
<b>Service A – Jezzine</b>		-	-	-	<b>00:15</b>	
1D	Service OUT	-	-	-	-	07:17
Refuel		<b>RZ 1</b>				
Distance to next refuel – RZ 2		36.71	68.00	104.71		
2	Bqosta	-	27.64	27.64	00:40	07:57
SS2	<b>BQOSTA 1</b>	<b>11.41</b>	-	-	-	<b>08:00</b>
3	Bisri	-	9.08	20.49	00:28	08:28
SS3	<b>BISRI 1</b>	<b>8.50</b>	-	-	-	<b>08:31</b>
4	Barti	-	24.00	32.50	00:45	9:16
SS4	<b>BARTI 1</b>	<b>16.80</b>	-	-	-	<b>9:19</b>
4A	Regrouping & Technical Zone IN	-	6.78	23.58	00:33	9:52
4B	Regrouping OUT	-	-	-	00:13	10:05
4C	Service IN	-	0.50	0.50	00:01	10:06
<b>Service B – Jezzine Main Square</b>		<b>36.71</b>	<b>68.00</b>	<b>104.71</b>	<b>00:45</b>	
4D	Service OUT	-	-	-	-	10:51
Refuel		<b>RZ 2</b>				
Distance to next refuel – RZ 3		36.71	68.00	104.71		
5	Bqosta	-	27.64	27.64	00:40	11:31
SS5	<b>BQOSTA 2</b>	<b>11.41</b>	-	-	-	<b>11:34</b>
6	Bisri	-	9.08	20.49	00:28	12:02
SS6	<b>BISRI 2</b>	<b>8.50</b>	-	-	-	<b>12:05</b>
7	Barti	-	24.00	32.50	00:45	12:50
SS7	<b>BARTI 2</b>	<b>16.80</b>	-	-	-	<b>12:53</b>
7A	Regrouping & Technical Zone IN	-	6.78	23.58	00:33	13:26
7B	Regrouping OUT	-	-	-	00:13	13:39
7C	Service IN	-	0.50	0.50	00:01	13:40
<b>Service C – Jezzine</b>		<b>36.71</b>	<b>68.00</b>	<b>104.71</b>	<b>00:45</b>	
7D	Service OUT	-	-	-	-	14:25
Refuel		<b>RZ 3</b>				
Distance to FINISH		36.71	67.50	104.21		
8	Bqosta	-	27.64	27.64	00:40	15:05
SS8	<b>BQOSTA 3</b>	<b>11.41</b>	-	-	-	<b>15:08</b>
9	Bisri	-	9.08	20.49	00:28	15:36
SS9	<b>BISRI 3</b>	<b>8.50</b>	-	-	-	<b>15:39</b>
10	Barti	-	24.00	32.50	00:45	16:24
SS10	<b>BARTI 3</b>	<b>16.80</b>	-	-	-	<b>16:27</b>
10A	Holding Area IN – Jezzine Main Square	-	6.78	23.58	00:33	17:00
<b>FINISH PODIUM</b>		-	-	-	-	<b>17:15</b>
<b>Sunday Totals</b>		<b>110.13</b>	<b>204.00</b>	<b>314.13</b>		

Sunday, June 9<sup>th</sup>, 2019:

Dawn: 03:45hrs.

Sunrise: 05:28hrs

Sunset: 19:47hrs



#### TOTALS OF THE RALLY

		SS	Liaison	Total	% of	%
Saturday, June 8 <sup>th</sup> , 2019	Section 1	1.20	0.23	1.43	<i>Special</i>	88.89%
Sunday, June 9 <sup>th</sup> , 2019	Sections 2, 3 and, 4	110.13	204.00	314.13	<i>Stages</i>	35.06%
<b>TOTAL – 10 Special Stages</b>		<b>111.33</b>	<b>204.23</b>	<b>315.56</b>		<b>35.29%</b>

## APPENDIX 2:

### RECONNAISSANCE SCHEDULE

# ALL COMPETITORS

**Start: Friday, June 7<sup>th</sup>, 2019 at 8:30hrs**

**End: Friday, June 7<sup>th</sup>, 2019 at 18:30hrs**

**SSS 1 Jezzine (g)**  
**SS 2 / 5 / 8 - Bqosta**  
**SS 3 / 6 / 9 – Bisri**  
**SS 4 / 7 / 10 – Barti**

- It is emphasized that reconnaissance is not a practice run. The competitors must drive in a manner that does not endanger or cause inconvenience to traffic or people living within and near the stages.
- Reconnaissance outside the aforementioned Reconnaissance Schedule, from the dates of publication of the itinerary to the Start of the Rally is **PROHIBITED**. The presence of any entrant and/or crew member entered in the rally on any part of a special stage, in any way whatsoever, is considered as reconnaissance. If any crew and/or competitor is found outside the Reconnaissance Schedule, on any part of any special stage to be used in the rally, he or she will be reported to the stewards who may apply penalties at their discretion.
- Crews will only be permitted to enter and leave special stages through the start and finish controls shown in the Road Book and may not under any circumstances drive in a direction opposite to that of the rally.
- The reconnaissance schedule starts on Friday 7<sup>th</sup> of June at 9:00hrs and ends at 18:00hrs. **Any competitor found in breach of this rule, shall be reported to the stewards who may apply penalties at their own discretion.**
- Maximum speed limit of 50 km/h during reconnaissance is imposed on all special stages, 30 km/h inside populated villages, unless another speed limit is indicated by traffic signs.
- All cars must have their headlights on at all times whilst travelling on the special stages.**
- Jezzine Super Special Stage Reconnaissance will be available on Friday 7<sup>th</sup> June from 16:00hrs till 16:30hrs ONLY and under the supervision of Jezzine Municipality police .**

## **APPENDIX 3:**

### **COMPETITORS' RELATIONS OFFICER**

The Competitors' Relations Officer is:



**Michael Schucry**

The Competitors' Relations Officer will be easily identified by his Pink shirt with "C.R.O." in white letters weaved on his right.

### **PRESENCE DURING THE RALLY:**

When the Secretariat is opened, a planning of the places and schedule where he will be on duties will be established. This planning will be post on the Official Notice Board and will include:

- Presence at Documentation and Scrutineering
- At the Secretariat of the Meeting.
- At the Start of the Rally.
- At the Regrouping halts.
- At the Service Parks.
- Near the Parc Fermé(s) and the Finish (the latter being dependent on the rally timetable).

### **FUNCTION:**

The principal duty of the CRO is to provide information or clarifications in connection with the regulations

### **MEDIATION:**

- Avoid forwarding questions to the stewards which could be solved satisfactorily by a clear explanation with the exception of protests (for example, clarify disputes over times, with the assistance of the time-keepers).
- The Competitor's Relations Officer shall refrain from saying anything or taking any action which might give rise to protests.

## **APPENDIX 4:**

### **IDENTIFICATION NUMBERS, ADVERTISING AND NAMES**

#### **Identification Numbers and Compulsory Advertising:**

- 1 2 x Door Panel with Competition Number 67x17cm. The top of the plate shall be placed between 7 cm and 10 cm below the bottom window line. No other signage shall be placed within 10 cm of the plate. (1)

#### **(Roof Panel (2) not applicable during the 8th Jezzine Rally)**

- 2 Rear window panel with Competition Number 30x10cm. It shall be positioned at the top of the rear window in a central location. An adjacent area of 15x15cm containing a 14cm high Competition Number coloured in fluorescent orange (PMS 804). The number must be visible from the rear at eye level. (3)
- 3 Front rally plate 43x21.5cm. (4)
- 4 Rear side windows: (5)  
2 x Competition Number 20 cm high with a stroke width of 25 mm coloured in fluorescent orange (PMS 804) shall be placed on the rear side windows adjacent to the crew's name.

The name of the driver with his/her passport nationality national flag must appear on the rear side window of both sides of the car (under the Competition Numbers). The Surname alone shall be:

- 5.1 In Helvetica upper case for the first letter of the name and the remainder in lower case
- 5.2 In white on a clear background.
- 5.3 To a height of 6cm. and a stroke width of 1.0cm.

#### **Organisers' Optional Advertising:**

- 1 A 10cm. high strip on the upper part of the windscreen, according to Article 16.7 of the 2019 International Sporting Code (6).
- 2 One space on each Front Door of the vehicle (67cm x 17cm) situated 10cms beneath the Door Panel (7).

A FURTHER BULLETIN WILL DETERMINE THE ADVERTISING BRANDS.

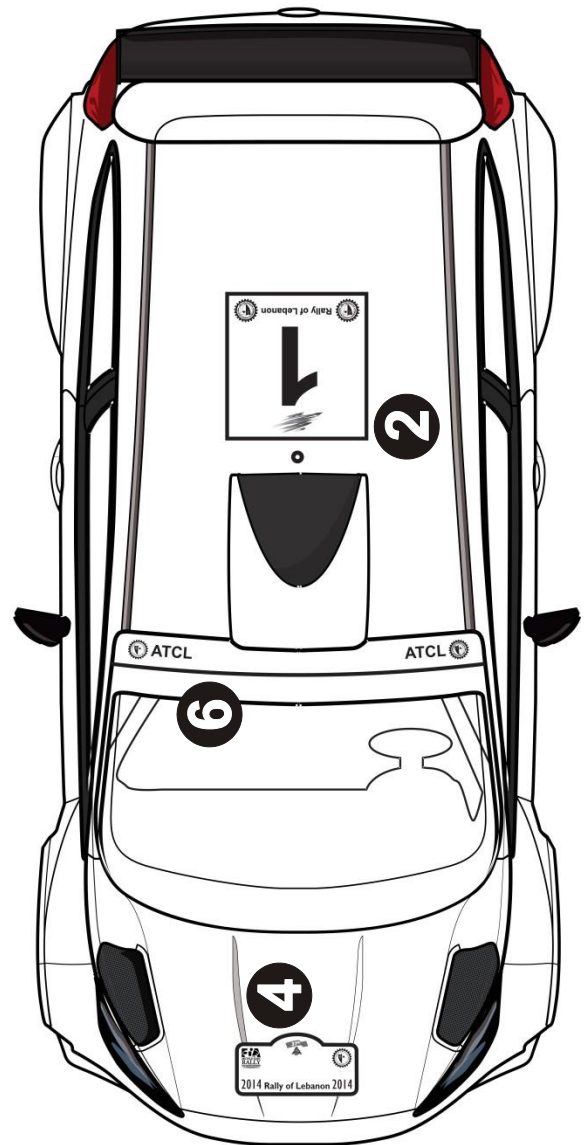
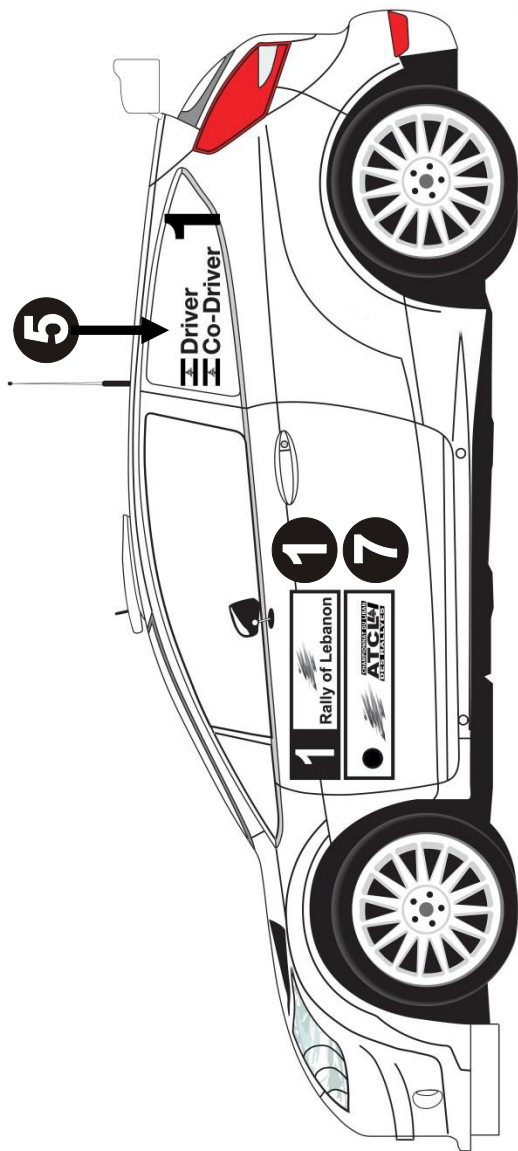
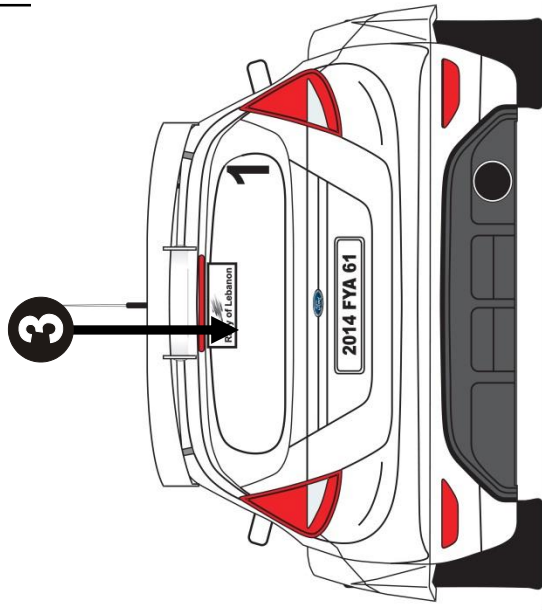

## **APPENDIX 5:**

### **EXTRACTS FROM FIA APPENDIX L**

#### **1. Helmets**

All drivers must wear crash helmets which meet one of the standards listed in FIA Technical List N° 25.

When the use of a Frontal Head Restraint system (FHR) is mandatory, only helmets approved in accordance with FIA standard 8858 (Technical List N°41), 8860 (Technical List N°33) or 8859 (Technical List N°49) are authorized.

#### **2. Flame-resistant clothing**

On special stages of rallies, all drivers and co-drivers must wear overalls as well as gloves (optional for co-drivers), long underwear, a balaclava, socks and shoes homologated to the FIA 8856-2000 standard (Technical List N°27).

Users must ensure that garments are not too tight, as this reduces the level of protection.

Embroidery sewn directly onto the overalls shall be stitched onto the outermost layer only, for better heat insulation. Backing material of badges and thread used for affixing them to the overalls must be flameproof.

Printing on drivers' clothing must be carried out only by the manufacturer of the product and must be flameproof and in conformity with the standard ISO 15025. It must not reduce heat transmission performance as defined in Appendix L, Article 8.2. (see Appendix 1 of the FIA 8856-2000 Standard for detailed requirements and instructions for use).

#### **3. Frontal Head Restraint (FHR)**

The wearing of any device intended to protect the head or neck and attached to the helmet is prohibited, unless the device has been homologated according to the FIA 8858 standard. Homologated FHR systems are listed in the FIA Technical List N° 29. The minimum reclined HANS collar angle shall be 60° from the horizontal.

Any padding used between the driver and the HANS® yoke must not be more than 15 mm thick when the driver is seated in the car fully equipped with the harness tightened. The padding must be covered by a flameproof material in conformity with the standard ISO 15025 and the padding must not be wider than 8 mm on each side of the HANS® yoke.

FHR systems must be worn only with FIA-approved items according to the following chart:

Helmet	Tether system (tether, tether end fitting and helmet anchorage)
FIA 8860 (Technical List N° 33) FIA 8858 (Technical List N° 41) FIA 8859 (Technical List N° 49)	FIA 8858 (Technical List N° 29)

For more details, when the device used is the HANS<sup>®</sup>, the “Guide for the Use of HANS<sup>®</sup> in international motor sport”, published by the FIA Institute for Motor Sport Safety, can be found on [www.fia.com](http://www.fia.com), under the heading FIA Sport - Regulations - Drivers’ Equipment.

#### 4. Safety Belts

Drivers must be properly restrained in their seat by safety belts in conformity with the specifications of Appendix J for the vehicle concerned, at all times during an event when it is mobile on a circuit, pit lane, special stage or competition course.



## APPENDIX 6:

### MOUNTING OF ON-BOARD CAMERAS INTERIOR / EXTERIOR

#### 1- INTERIOR MOUNT

The mounting should be of a rigid type, placed in the centre behind the back of the seats.

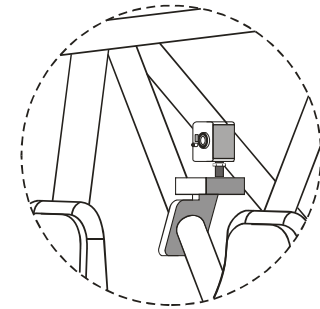
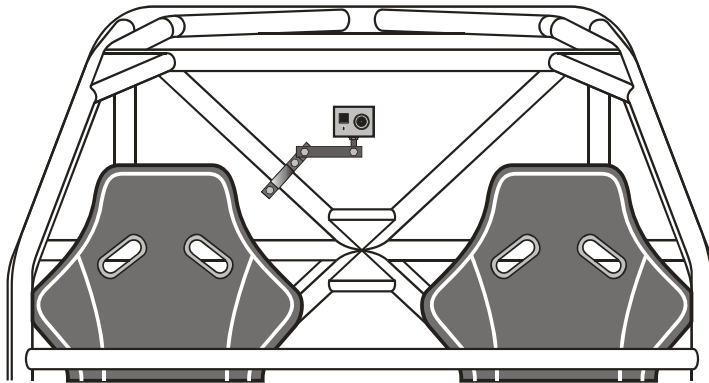

**Handlebar Mount**



For pencil type cameras, they can be mounted on the front rollbar windscreen pillar, the control unit should be fixed on the floor pan behind the seats. (Similar to battery fixation)

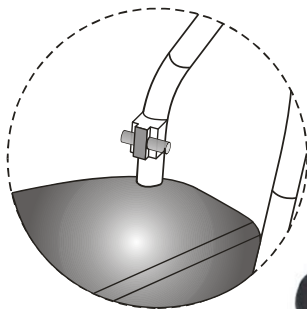

On front Rollbar

**OR**

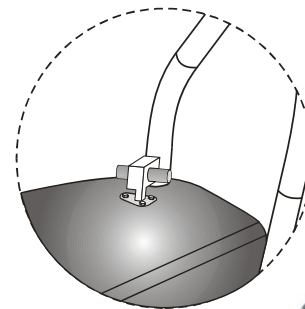

On dashboard



## 2- EXTERIOR MOUNT

A support bracket of 40mm. fixed by screws with a reinforcement plate of minimum 3mm thick and a surface of 120 cm<sup>2</sup> should be used

**IMPORTANT: The reinforcement plate should be placed from inside the body work in order to reinforce the support area.**

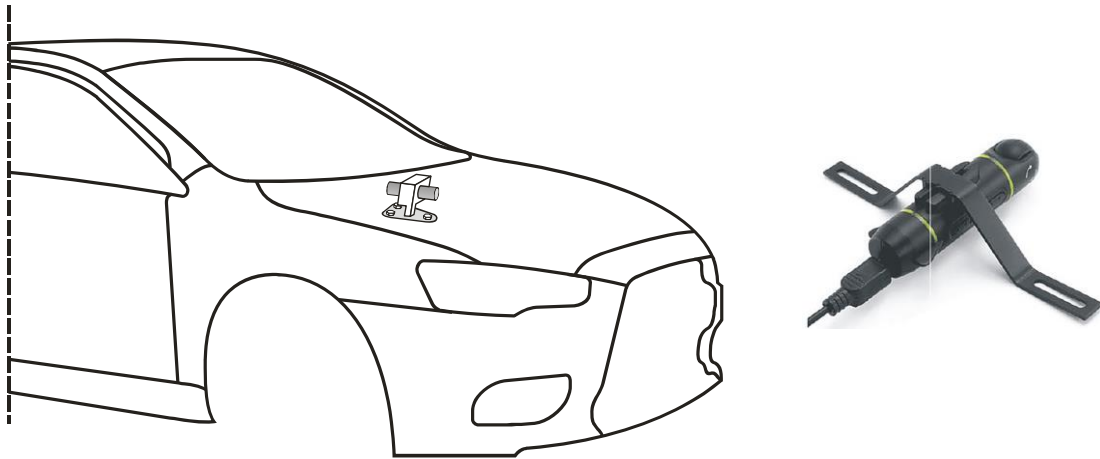

## 3- PROHIBITED MOUNTINGS

