

34TH SPRING RALLY

April 22nd, 2018



SUPPLEMENTARY REGULATIONS



Organised by

The Automobile and Touring Club of Lebanon
P.O. Box 115 - Jounieh / Lebanon
Tel.: +961-9-640220 / 640567 / 932020
Fax: +961-9-640579 / 934662
e-mail: atcl@inco.com.lb
web site: www.atcl.org



CHAMPIONNAT DU LIBAN
ATCL
DES RALLYES

CONTENTS:

	<u>Page</u>
1. Introduction	3
2. Organisation and Description	3
3. Programme and Deadlines	5
4. Entries	7
5. Insurance	10
6. Advertising & Identification Numbers	11
7. Tyres	12
8. Fuel	12
9. Reconnaissance	14
10. Administrative Check	16
11. Scrutineering, Sealing and Marking	17
12. Other Procedures	20
13. Identification of Officials	21
14. Prizes	22
15. Final Checks and Protests	23
APPENDIX 1 Itinerary	24
APPENDIX 2 Reconnaissance schedule	25
APPENDIX 3 Name and photograph of CRO	26
APPENDIX 4 Advertising and Identification Numbers	27
APPENDIX 5 Extracts from FIA Appendix L	29
APPENDIX 6 Extracts from 2018 FIA Regional Rally Sporting Regulation	31
APPENDIX 7 Mounting of On-Board Cameras	33

1 - INTRODUCTION:

1.1 - Announcement

This rally will be run in compliance with the FIA International Sporting Code and its appendices, the 2018 FIA Regional Rally Sporting Regulations, the National Sporting Code which comply with the FIA regulations and these Supplementary Regulations.

Modifications, amendments and/or changes to these Supplementary Regulations will be announced only by numbered and dated bulletins (issued by the Organiser, the Clerk of the Course or the Stewards).

1.2 - Road surface

The rally will be run on **Tarmac**.

1.3 - Overall SS distance and total distance of the itinerary

SS distance: **92.73 kms.**

Total distance: **328.49 kms.**

2 - ORGANISATION AND DESCRIPTION

2.1 – National titles for which the rally counts:

- The 2018 Lebanese Rally Championship for Drivers.
- The 2018 Lebanese Rally Championship for Co-Drivers.
- The 2018 Lebanese Cup for RC2/N4 Rally Drivers.
- The 2018 Lebanese Cup for RC3 Rally Drivers.
- The 2018 Lebanese Cup for RC4 Rally Drivers.
- The 2018 Lebanese Cup for RC5 Rally Drivers.
- The 2018 Lebanese Cup for Junior Rally Drivers/Co-Drivers.
- The 2018 Ladies Cup for the Lebanese Championship.

2.2 - Visa numbers - ASN:

ASN visa No: **R/1/2018**

Issued on: **February 26th, 2018**

2.3 - Organiser's name, address and contact details (permanent office)

The Automobile and Touring Club of Lebanon
Kaslik; Jounieh
National Sporting Committee / Permanent Secretariat
34th Spring Rally Office

P.O. Box 115 - Jounieh / Lebanon
Tel.: +961-9-640220 / 640567 / 932020
Fax: +961-9-640579 / 934662
e-mail: atcl@inco.com.lb
website: www.atcl.org



CHAMPIONNAT DU LIBAN
ATCL
DES RALLYES

2.4 - Organisation committee:

Chairman	Gaby Hayek
Members	Fady Aoun (<i>alphabetical order</i>) Nicolas Hindi Dr. Guy Hokayem Me. Ziad Jamous Raffi Khederlarian Lian Tawtah

2.5 - Stewards of the Meeting:

Chairman of the Panel	Issam El Hitti (Chairman) Sleiman Khattar Fady Aoun
Secretary to the Stewards	Joelle Daou

2.6 - Observers and Delegates:

ASN Sporting Delegate	Gaby Kreiker
-----------------------	--------------

2.7 - Senior Officials:

Clerk of the Course	Gaby Hayek
Deputy Clerk of the Course	Lydia Labaki
Chief Safety Officer	Nicolas Hindi
Scrutineers	Raffi Khederlarian (Chief) Georges Haddad Hovsep Aslanian Khalil Hashem Ardem Sarkissian Carl Aoun Anthony Bassil
Competitors' Relations Officer	Michel Schucry
Chief Medical Officer	Dr. Guy Hokayem
Media Relations Officer	Jalal Beaino
Tracking Monitoring Officer	Neman Hatem
Results Officer	Fady Eid
Secretary of the Rally	Joelle Daou
Judges of Fact:	All the named officials on this page.

2.8 - HQ location and contact details

The Rally HQ is located at:

Casino du Liban
Maameltein; Lebanon

E-mail: atcl@inco.com.lb

Web site: www.atcl.org

2.9 - Location of Holding Area:

The Holding Area is located at Casino du Liban – Maamltein;

2.10 - Location of Service park(s):

The Service Park(s) are located at LBCI Parking – Adma.

3 - PROGRAMME AND DEADLINES: (IN CHRONOLOGICAL ORDER)

Friday March 23rd 2018

10:00hrs	Opening date for entries.	Rally Office A.T.C.L.; Jounieh
----------	---------------------------	-----------------------------------

Monday April 16th 2018

12:00hrs	Submittal of Fuel Purchase Form.	TOTAL Liban Ashrafieh; Beirut
16:30hrs	Closing date for entries.	Rally Office A.T.C.L.; Jounieh
16:30hrs	Closing date for co-driver details.	Rally Office A.T.C.L.; Jounieh
16:30hrs	Closing date for submitting all forms	Rally Office A.T.C.L.; Jounieh

Tuesday April 17th 2018

10:00hrs	Publication of the Entry List on the official notice board.	A.T.C.L.; Jounieh
16:00hrs	Publication of convocations to administrative checks and scrutineering.	Rally Office A.T.C.L.; Jounieh

Wednesday April 18th 2018

08:00 till 11:00hrs	Collection of material and documents.	Rally Office A.T.C.L.; Jounieh
09:00hrs	Opening of media centre and media accreditation.	Rally Office A.T.C.L.; Jounieh

Thursday April 19th 2018

09:00 till 15:00hrs	Issuing of the Road-Book.	Rally Office A.T.C.L.; Jounieh
---------------------	---------------------------	-----------------------------------

Friday April 20th 2018

08:00hrs	Reconnaissance starts	
17:00hrs	Reconnaissance ends.	
18:00 till 21:30hrs	Administrative Checks	Silo Motors



	(Convocations will be carried out according to an individual time schedule).	Qunabat Broumana
18:30 till 22:00hrs	Scrutineering - sealing and marking (The administrative checks must be completed before the scrutineering of the cars. Convocations will be carried out according to an individual time schedule).	Silo Motors Qunabat Broumana
19:30hrs	Compulsory Drivers briefing.	Silo Motors Qunabat Broumana
22:15hrs	First stewards' meeting	Silo Motors Qunabat Broumana
Saturday April 21st, 2018		
11:00hrs	Publication of Start List for Section 1/ Leg 1, on the official notice board.	Rally Office A.T.C.L.; Jounieh
Sunday April 22nd, 2018		
05:30hrs	Opening of the Rally Headquarters.	Casino du Liban Maameltein; Lebanon
06:30 till 07:00hrs	Car entry to the starting Holding Area.	Casino du Liban Maameltein; Lebanon
07:30hrs	Rally Start.	Casino du Liban Maameltein; Lebanon
17:30hrs	Finish Ceremony and Prize-giving.	Casino du Liban Maameltein; Lebanon
18:00hrs	Final scrutineering.	Casino du Liban Maameltein; Lebanon
18:45hrs	Publication of the Provisional Final Classification.	Casino du Liban Maameltein; Lebanon
19:15hrs	Publication of the Official Final Classification.	Casino du Liban Maameltein; Lebanon

Official Notice Board

- Thursday March 15th, 2018 to Saturday April 21st 2018
Rally Secretariat
The Automobile and Touring Club of Lebanon
Kaslik; Jounieh
National Sporting Committee Office
- Sunday April 22nd, 2018
Rally Headquarters
Casino du Liban
Maameltein; Jounieh

4 - ENTRIES

4.1 – Closing date for entries:

Monday, April 16th, 2018 at 16:30hrs

4.2 - Entry procedure:

Any person wishing to take part in the 34th Spring Rally must complete and send the entry form (including co-driver details) to the Rally Office (for address details please refer to Art. 2.3 of this Supplementary Regulations).

All entry forms must be signed by the entrant and each crew member prior to the start of testing and/or reconnaissance. Foreign competitors must hold an authorisation from their parent National Sporting Authority.

Entry forms will only be accepted if accompanied by:

- The total amount of the entry fees.
- Photocopy of the first page of the homologation book for the car.
- Photocopy of the entrant / competitor licence.
- Photocopies of crew members' competitions licences.
- Photocopies of crew members' valid driving licences.
- A letter from the owner of the car and/or a power of attorney (if the car is not the property of the crew members).

4.3 - Number of entrants accepted and classes:

The maximum number of entries is 40 cars. If more than 40 entries are received, the Organisers reserve the right to decide which entries (among the non-priority drivers) to be accepted.

4.3.1 – Classes and Groups:

Classes	Groups
RC2/-N4	S2000-Rally: 1.6 T engine with a 28mm restrictor.
	S2000-Rally: 2.0 Atmospheric.
RC2/N4	Group R5 (VR5).
	Group R4 (VR4) (not eligible in Europe).
RC2/N4	Group N car over 2000cc (current N4).
RGT*	* RGT cars are excluded.
RC3	Group A car over 1600cc and up to 2000cc.
	Super 1600.
	R2 (atmo over 1600cc and up to 2000cc – VR2C and turbo over 1067cc and up to 1333cc – VR2C).
	R3 (atmo / over 1600cc and up to 2000cc – VR3C and turbo over 1067cc and up to 1333cc – VR3C).
	R3 (turbo / up to 1620cc / nominal – VR3T).
	R3 (diesel / up to 2000cc / nominal – VR3D).
RC4	Group A up to 1600cc.

	R2 (atmo over 1390cc and up to 1600cc – VR2B and turbo over 927cc and up to 1067cc – VR2B).
	Kit-car up to 1600cc.
	Group N car over 1600cc and up to 2000cc.
RC5	Group N car up to 1600cc.
	R1 (atmo up to 1600cc - VR1A/VR1B and turbo up to 1067cc - VR1A/VR1B).

4.3.2 –Additional Provisions:

- Cars homologated as Kit cars, where the capacity is between 1400 and 1600cc, may be accepted if they also comply with Article 255-6.2 “Weight” of Appendix J.
- Two-wheel drive cars equipped with a supercharged diesel engine with a nominal cylinder capacity of less than 2000cc are accepted in Groups A and N.
- For drivers entered with a Super 2000-Rally car complying with 2013 Art. 255A, it will be possible to use lapsed errata without any penalty.
- For Super 1600 homologated cars, it will be possible to use lapsed errata without any penalty.

4.3.3 – National Cars:

In Compliance with Article 4.4 of the 2018 FIA Regional Rally Sporting Regulations and Article 6.2.b, Appendix A of the 2018 National Sporting Code, furthermore, Groups A (**excluding A8 and WRC vehicles**), and N cars or their equivalent Classes RC2 to RC5 whose homologations have expired up to a maximum of **TEN** years before the beginning of the current year, and with a valid FIA passport, are permitted to participate in the 34th Spring Rally. **RGT cars are excluded.**

These cars may only be accepted for participation if the correct, though expired, homologation papers are produced at documentation and at scrutineering and the cars remain in total conformity with the original technical specifications and are in a sound condition to participate, at the discretion of the scrutineers.

The size of turbo restrictors used on turbo-equipped cars and the minimum weight are those currently valid.

FIA and Lebanese ASN seeded drivers are not permitted to drive such cars in the 34th Spring Rally.

4.3.4 - PROMOTION classification

There will be a PROMOTION classification for the Lebanese competitors with the following conditions:

- To hold the Lebanese nationality and competition licence.
- Not to be F.I.A. priority driver.
- Not to be MERC priority driver.
- Not to be an A.S.N. priority driver.
- The car must be the property of one of the crew members and not the property of any dealer or manufacturer.

- f) Have not been classified among the first 3 during the past two years at the Rally of Lebanon.

A list of PROMOTION classification will be issued at the same time along with the entry list.

4.4 - Entry fees and entry packages:

4.4.1 The entry fees are as follows:

- a) With the optional advertising proposed by the Organisers
- * For Private Entrant USD750. - U.S. \$
 - * For Legal Entrant USD1,500. - U.S. \$
- b) Without the optional advertising proposed by the Organisers
- * For Private Entrant USD1,500. - U.S. \$
 - * For Legal Entrant USD3,000. - U.S. \$

Private Entrant: For an entry for the 34th Spring Rally to be considered as a private entry, the following conditions must be complied with:

- a) The car entered must be personal property of one of the crew members and the car licence must be in his/her name.
If the car is not the property of one of the crew members, a letter of authorisation from the owner of the car and/or a power of attorney approving the use of the car should be accompanied along with the entry form.
Letters of authorisation and/or powers of attorney dated more than three months before the date of the rally will not be considered.
- b) The entry form must be made in the name of one of the crew members, not in the name of a sponsor or any commercial organisation.
- c) The entrant's competition licence must be in the name of one of the crew members.

Unless all of the above mentioned conditions are met, the entry will not be considered as a private entry and the appropriate entry fees will be liable for payment.

Legal Entrant: The competing car entered by a team, a manufacturer, a company or other legal entity (with legal entrants / competitors licence).

4.4.2 The entry fees specified in Article 4.4.1 (aforementioned) include:

Item	Private Entrants	Legal Entrant
Driver Passes	2	2
Service Personnel Passes	6	12
"Service" plates	1	2
Road Book	1	1

Should additional material deem necessary; it can be ordered from the rally secretariat by using the "Additional materials order form".



4.4.3 The change of one crew member will be subject to article 21.5 of the 2018 FIA Regional Rally Sporting Regulations. However, an additional fee of 50.- U.S. \$ will be imposed in case of changing a crew member.

4.5 - Payment details:

Entry Fees can be remitted to the Organiser's Bank Account:

Bank: BLOM Bank (Banque du Liban et d'Outre-Mer)
Bank address: Kaslik Branch
Account N°: 023 - 02(300) 067 36 21 - 1 - 6(44037) and to the order of
The Automobile and Touring Club of Lebanon
IBAN: LB21 0014 0000 2302 3000 6736 2116
SWIFT CODE: BLOMBBX

Any bank charges incurred by a swift transfer must be charged to the sender's account.

Entry fees paid by bank transfer shall simultaneously be advised to the Rally Office by fax and/or e-mail to ensure that payment is received in full prior to the close of entries.

4.6 - Refunds:

Entry fees will be refunded in full:

- a) To candidates whose entry has not been accepted.
- b) In case the 34th Spring Rally does not take place.
- c) Organisers may refund up to 30% of the entry fee to those competitors who, for reasons of "force majeure" (duly certified by their ASN), were unable to start in the rally.

5 - INSURANCE

- a) The insurance guaranties the competitors for civil liability towards third parties for a maximum of USD 100.000 as total liability for this event. The insurance cover will come into effect from the start until the end of the rally or at the moment of permanent retirement, disqualification or exclusion.
- b) Beside the insurance provided by the organisers, it is compulsory for all entrants / competitors to have their rally vehicle covered by a third party liability, during their stay in Lebanon.
A copy of the insurance certificate should be presented along with other documents upon administrative checks (refer here under to Art. 10.3 of these Supplementary Regulations).
- c) It is mandatory that all foreign crew members have Motor Sport Personal Accident Insurance valid for Lebanon, or a Prise en Charge issued by the crew members parent ASN. Otherwise, the Organiser will provide such insurance for a premium of 250. - U.S. \$.
- d) The service, management vehicles and reconnaissance vehicles including those bearing special plates issued by the Organisers may never be considered as official participants in the rally. They are therefore not

covered by the insurance policy of the rally and will remain the sole responsibility of their owners.

- e) Damages to rally cars as well as liability of a crew member towards the other crew member or car are not covered by the insurance provided by the Organisers.

- f) **Accident Reporting:**

In compliance with Article 40.3 of the 2018 FIA Regional Rally Sporting Regulations, “if a crew is involved in an accident in which a member of the public sustains physical injury, the driver or co-driver concerned must remain at the scene and stop the following car, which must report this to the next radio point as specified in the road book and signed on the route. All crews stopped by this procedure will be allocated a time according to Article 39 of the 2018 FIA Regional Rally Sporting Regulations.

However, if the driver fails to observe this rule, the stewards of the meeting may impose on the responsible crew a penalty which may go as far as exclusion.

Moreover, it is compulsory for the competitor or his representative to notify the Clerk of the Course and/or the Competitor's Relations Officer(s) in writing within 4 hours with the full details including the names and addresses of those involved and witnesses if any.

6 - ADVERTISING AND IDENTIFICATION

6.1 - Advertising:

- a) The advertising of tobacco products is allowed on the condition of mentioning the required warnings recommended by the Lebanese government according to the Lebanese law at the time of going to print.
- b) Advertising regarding alcoholic beverages is permitted.
- c) The advertising of political, religious and/or social material is strictly forbidden.
- d) Competition numbers, rally plates and advertising shall be affixed on the car before scrutineering. These must be visible through the whole duration of the rally under the pain of penalty (Article 6.2-b of these Supplementary Regulations.).
- e) Spaces set by the Organisers (refer to Appendix 4 of this Supplementary Regulation) must be reserved on the car, if the entrant has accepted the Organiser's optional advertising, unless he pays the Entry Fees without Optional Advertising proposed by the Organisers in accordance with Article 4.4.1-b of this Supplementary Regulation.

6.2 - Identification numbers:

- a) The rally plates and numbers will be provided by the Organisers in compliance with the FIA Regional Rally Sporting Regulations. These numbers must be affixed as specified in Appendix 4.
- b) The missing and/or covering of a rally plate will result in a cash penalty of 100. - U.S. \$
- c) Service and/or auxiliary vehicle plates shall be affixed on the inside of the windscreen in the top right hand corner.

7 – TYRES

- a) All tyres must comply with Article 60 of the 2018 FIA Regional Rally Sporting Regulations read in conjunction with Appendix V, Article A - Tarmac Tyre Regulations.
The list of eligible asphalt tyres for FIA rallies, which are the only tyres allowed, can be found on the FIA website under the following link:
https://www.fia.com/sites/default/files/2018_asphalt_tyre_fia_eligibility_13.02.2018.pdf
- b) The use of slick tyres is prohibited.
- c) In accordance with Article 60.1.6 of the 2018 FIA Regional Rally Sporting Regulations, the use of any device for maintaining the full performance of the tyre with an internal pressure equal to or less than atmospheric pressure is forbidden. The interior of the tyre (the space between the rim and the internal part of the tyre) must be filled only with air.
- d) In accordance with Article 60.13 of the 2018 FIA Regional Rally Sporting Regulations, all tyres used in this rally must be readily available commercially.
- e) Tyre changes may only be carried out in authorised zones.
- f) Tyre marking zones will be organised after the exit TC of the Service Park.
- g) Any breach of the tyre regulations will be submitted to the Stewards and may result in a penalty, which may go as far as the exclusion of the crew by the Stewards.

8 – FUEL

8.1 Fuel supply

- 8.1.1** - Throughout the 34th Spring Rally all entered cars shall **SOLELY** use fuel supplied by “TOTAL Liban”, which meets the technical requirements of FIA Appendix J.

8.1.2 - Two types of petrol are available:

- a) ELF TURBO REF (50 litre canisters), sold at the price of \$ **7.70** /litre VAT included.
- b) TOTAL EFFIMAX 98 octane, sold at current price of the market at delivery time, VAT included.

8.1.3 - “TOTAL Liban” will supply the fuel needed for the adjustments, against request and upon payment.

8.1.4 - Closing date for ordering fuel

- a) Each competitor must fill in and submit the special Fuel Purchase Form requesting the quantity of fuel needed for the rally and send it, no later than 12:00hrs on Monday, April 16th, 2018, to:

TOTAL Liban
Tilal Beirut Bldg., 2nd floor
Rue Ashrafieh
Ashrafieh; Beirut; Lebanon
P.O. Box 11-3636 - Beirut / Lebanon
Tel.: +961-1-212250 Fax: +961-1-216014
e-mail: michel.hajjar@total-liban.com

- b) Payment details:

Payments can be remitted to the supplier’s bank account:

Bank: Bank Audi
Bank address: Centre SOFIL, Ashrafieh Branch
IBAN: LB86 0056 0002 0206 7421 0020 0936
Devise: USD
SWIFT CODE: AUDBLBBX

Any bank charges incurred by a swift transfer must be charged to the sender's account.

Moreover, a copy of fuel purchase invoice should be presented along with other documents in the administrative checks.

In case of failure to collect part of the fuel, the purchaser will be refunded with the corresponding amount of the remaining fuel in sealed canisters ONLY for TURBO, Turbo REF Type, within 15 days after the end of the rally.

8.1.5 Fuel dispense

The fuel will be dispensed to the competitor or his representative (duly assigned in writing) at the refuelling zone – as indicated in the Road-Book - subject to presenting the voucher given by “TOTAL Liban” and in compliance with the schedule filled on the Fuel Purchase Order and mutually agreed upon between “TOTAL Liban” and the purchaser.

It is the competitors’ responsibility to fill the appropriate form given by TOTAL Liban regarding the quantity to be dispensed at each of the refuelling zones in the rally.

8.2 General provisions

- a) The fuel tank capacity should meet and cover the time and distance table of the rally, *i.e. the rally itinerary*.
- b) Except as detailed under Article 50 and in accordance with Article 58.1 of the 2018 FIA Regional Rally Sporting Regulations, competitors may only refuel in the refuel zones designated by the Organisers in the road-book. Other activities inside the refuelling zone are strictly prohibited.
Any breach of these regulations will be reported to the Stewards who may apply penalties at their discretion which may go as far as the exclusion of the crew.
- c) Refuelling procedure (Article 58 of the 2018 FIA Regional Rally Sporting Regulations):
 - Only actions inside a refuelling zone directly involved in the refuelling of the competing vehicle are permitted.
 - In all refuelling zones, a 5 kph speed limit will apply.
 - The responsibility for refuelling is incumbent on the competitor alone.
 - It is **MANDATORY** for the relevant personnel for the refuelling to be wearing clothing which will provide adequate protection against fire.
 - Engines must be switched off throughout the refuelling operation.
 - It is recommended that the crew remains outside the car during refuelling; however, should they remain inside, their safety belts must be unfastened.
 - Solely for the purpose of assisting with the refuelling procedure of their car, two team members of each crew may access this zone.
 - A car may be pushed out of the zone by the crew, officials and/or the two team members without incurring a penalty.
- d) The organisers may make provisions for additional refuelling zones. However, these additional zones shall only be positioned along the itinerary. Except for refuelling rally vehicles, any other kind of servicing is strictly prohibited.

Any breach of the fuel and/or refuelling regulations will be submitted to the Stewards and may result in a penalty, at their discretion, which may go as far as the exclusion.

9 - RECONNAISSANCE

9.1 - Procedure for registration:

- a) Reconnaissance Cars must be in conformity with Article 25.1 of the 2018 FIA Regional Rally Sporting Regulations, and must be covered by insurance as required by the traffic laws of Lebanon, no responsibility being imputable to the organisers.
- b) When registering for reconnaissance, one of the crew members must be present to sign an indemnity and register the details of the

reconnaissance car (spare recce car, if any), mobile telephone number and contact details of the place of residence.

- c) The Reconnaissance Registration Form can be collected from the Rally Secretariat or downloaded from the A.T.C.L. official website. This form should be filled and sent to the Rally Secretariat before commencing the reconnaissance.

9.2 – Reconnaissance Schedule:

The road book will be issued on Thursday, April 19th, 2018, and will be distributed between 9:00 and 15:00hrs.

The Reconnaissance Schedule starts on Friday, April 20th, 2018, at 08:00hrs and ends at 17:00hrs.

The Reconnaissance is restricted to THREE PASSAGES ONLY, per super stage.

Any competitor found in breach of this article, will be reported to the stewards who may apply penalties at their discretion.

9.3 - Specific and national restrictions – speed limit:

- a) Reconnaissance outside the aforementioned Reconnaissance Schedule, Article 9.2 of this Supplementary Regulation, as from the dates of publication of the itinerary on the ATCL official website, to the date and time of the Start of the Rally is **PROHIBITED**. The presence of any driver or co-driver, or any other team member who has entered or intends to enter in the 34th Spring Rally, outside the Reconnaissance Schedule, on any part of a special stage to be used in the rally, in any way whatsoever, is considered as **Illegal Reconnaissance**, and a breach of this supplementary regulations; he or she will be reported to the stewards who may apply penalties at their discretion.
- b) Crews will only be permitted to enter and leave special stages through the start and finish controls shown in the Road Book and may not under any circumstances drive in a direction opposite to that of the rally.
- c) Maximum speed limit of 70 km/h during reconnaissance is imposed on all special stages, unless another speed limit is indicated by traffic signs. In compliance with Article 20.2.2 of the 2018 FIA Regional Rally Sporting Regulations, speeding during reconnaissance will incur a fine applied by the clerk of the course as follows:
- Per km per hour over the speed limit: € 25

The amount of this fine will be unaltered by any fine imposed by the police.

The fine will be doubled in case of a second offence committed during reconnaissance in the same rally.

Other traffic infringements during reconnaissance will incur a fine applied by the Steward.

- d) All cars must have their headlights on at all times whilst travelling on the special stages.
- e) Any breach of the reconnaissance regulations, of the 2018 FIA Regional Rally Sporting Regulations and these Supplementary Regulations, will



result in a penalty, which may go as far as exclusion, at the discretion of the Stewards.

9.4 - Fitment of speed control checking devices:

It is emphasized that reconnaissance is not a practice run. The competitors must drive in a manner that does not endanger or cause inconvenience to traffic or people living within and near the stages. During reconnaissance, the traffic laws of Lebanon must be strictly complied with as well as the safety and rights of ways of other road users should be respected.

The police may check the speed on the road sections and the special stages using speed check equipment.

9.5 – Compulsory Drivers Briefing

A briefing will be given to the competing crews by the clerk of the course, his deputy and/or by an appointed official.

The briefing will target specific points of the Supplementary Regulations relating to the organisation of the event, give any clarification concerning the interpretation of the regulations, and to remind the drivers of the safety provisions, either specific and/or general.

The participation of both or one of the crew members is compulsory.

Team managers may attend the meeting.

The briefing will be held at 19.30hrs on Friday, April 20th, 2018 at **Silo Motors - Qunabat Broumana**.

A fine of € 100 will be applied, by the clerk of the course, on each crew member who does not attend the briefing.

9.6 - Comment on tyres:

Complying with Article 25.2.a of the 2018 FIA Regional Rally Sporting Regulations, road-homologated series production tyres for asphalt are to be used for reconnaissance.

Any breach of the reconnaissance regulations, will result in a penalty at the discretion of the Stewards, which may go as far as exclusion. Furthermore, the Stewards may report the competitors concerned to the CSN for possible further sanctions.

10 - ADMINISTRATIVE CHECKS

10.1 - Location:

Administrative checks shall take place on Friday, April 20th, 2018 at the:

Silo Motors
Qunabat Broumana

Address: On the way down from Jouret El Ballout roundabout, before 500m from Qunabat Broumana Municipality, on the left hand side.

Tel: 71-122997; 03-587496

Both crew members have to attend the administrative check. However, Legal Entrants as well as FIA and ASN priority drivers may appoint a representative and/or a team manager (duly assigned in writing) for their entries.

10.2 - Times / schedule:

From 18:00hrs till 21:30hrs, according to an individual time schedule given later in a bulletin or a communication and posted on the official notice board at The Automobile and Touring Club of Lebanon; Jounieh - Lebanon.

Any crew reporting outside their time limits for Administrative Checks will be penalized 15. - U.S. \$ per minute to maximum of 15 minutes. Thereafter, they will be reported to the Stewards who may apply penalties at their discretion.

10.3 - Documents to be presented:

The following items will be checked at Administrative Checks:

- Entrants' licence (if any).
- Drivers' and Co-drivers' competition licences.
- Valid drivers' and Co-drivers' driving licences.
- Rally car documents and registration papers etc...

If the car is not the property of one of the crew members, a letter of authorisation from the owner of the car and/or a power of attorney approving the use of the car should be accompanied along with the entry form.

Letters of authorisation and/or powers of attorney dated more than three months before the date of the rally will not be considered.

- Insurance policy covering the rally vehicle (refer to Art. 5.b of these Supplementary Regulations).
- Motor Sport Personal Accident Insurance (Refer to Art. 5.c, of these Supplementary Regulations).
- Copy of fuel purchase invoice.
- Correctness and completion of all information given on the entry form.
- Authorisation for the drivers by their ASN to take part in the rally should be presented.
- Drivers' and co-drivers' medical certificates of aptitude valid for the current year as given to them by their parent ASN. These certificates must be in accordance with the ISC Appendix L, Chapter II, Article 1.8.

Competitors are required to hold a signed Administrative Clearance Form prior to Scrutineering.

11 - SCRUTINEERING, SEALING AND MARKING

The Administrative Check must be completed prior to Scrutineering. Competitors are required to present their signed Administrative Clearance Form prior entering the Scrutineering venue.

11.1 - Location:

Scrutineering, Sealing and Marking will take place on Friday, April 20th, 2018 at the:

Silo Motors
Qunabat Broumana

Address: On the way down from Jouret El Ballout roundabout, before 500m



from Qunabat Broumana Municipality, on the left hand side.
Tel: 71-122997; 03-587496

Both crew members have to attend the Scrutineering. However, Legal Entrants as well as FIA and ASN priority drivers may appoint a representative and/or a team manager (duly assigned in writing) for their entries.

Times / schedule:

From 18:30hrs till 22:00hrs, according to an individual time schedule given later in a bulletin or a communication and posted on the official notice board at the Automobile and Touring Club of Lebanon; Jounieh - Lebanon.

Any crew reporting outside their time limits for Scrutineering will be penalized 15. - U.S. \$ per minute to maximum of 15 minutes. Thereafter, they will be reported to the Stewards who may apply penalties at their discretion.

11.2 - Windows/Nets:

In compliance with the traffic law of Lebanon, **the use of silvered or tinted film is NOT AUTHORISED** on the side as well as the rear windows.

However, and in compliance with Appendix J, Article 253.11, the use of transparent and colourless anti-shatter films on the side windows and the glass sunroof is mandatory.

11.3 - Driver's safety equipment:

- The control of drivers' helmets and equipment as well as the head restraint (FHR device) will take place at the scrutineering. The helmets must meet one of the standards listed in technical list No. 25 of Appendix J. Each helmet used by the crew will have to be identified and marked during the scrutineering before start. This marking may be checked on the start of each special stage.

Drivers 'and co-drivers' overalls as well as gloves (optional for co-drivers), long underwear, a balaclava, socks and shoes should be homologated to FIA 8856-2000 standard.

- In compliance with ISC Appendix L, Chapter III, Article 3, the wearing of an FIA approved Frontal Head Restraint (FHR), homologated according to the FIA 8858 standard, on special stages is MANDATORY for all drivers and co-drivers. Homologated FHR systems are listed in the FIA Technical List N° 29.
- In compliance with Appendix L, Chapter III, Article 2, the wearing of long underwear homologated to the FIA 8856-2000 standard on special stages is MANDATORY for all drivers and co-drivers. (Technical List N°27).
- Infringements are subject to the penalty of refusal to take the start.
- In compliance with ISC Appendix J, Article 253.8.3.5, where the occupants' bodies could come into contact with the safety cage, flame

retardant protective padding must be provided for protection. All tubes of the cage and all roof reinforcements must be fitted with paddings in compliance

with FIA standard 8857-2001 type A; refer to *Technical List No. 23*. Each padding must be fixed in such a way that it is not moveable from the tube.

11.4 - Scrutineering requirements:

- Cars must be presented to the scrutineers with the competition numbers, rally plates and optional advertising affixed on the car before entering the Scrutineering venue. Failing to comply with this rule is subject to a cash penalty of 100. - U.S. \$ (Article 6.2.b of these Supplementary Regulations).
- In accordance with Article 26.1 of the 2018 FIA Regional Rally Sporting Regulations **the presentation of the car's complete original FIA homologation form in scrutineering is compulsory**. Any breach of these regulations will be reported to the Stewards who may apply penalties at their discretion.
- In accordance with Appendix J, Article 253.6, two belt cutters must be carried on board at all times. They must be easily accessible for the driver and co-driver when seated with their harnesses fastened.
- An authentic copy of the homologation document or certificate, of the rollage approved by the ASN and signed by qualified technicians representing the manufacturer, must be presented to the event's scrutineers
- Lighting:
In accordance with Appendix J of the International Sporting Code, Additional headlights are allowed, provided that the total number of headlights equipping the car does not exceed 8.
Headlights and other exterior lights must always exist in pairs
- **In accordance with Appendix J, Article 252-3.6, “all cars used in Rallies ..., the noise level on the open road must not exceed 103 dB(A) for an engine rotation speed of 3500 rpm for petrol engines”.**
- In accordance with Article 40.2 of the 2018 FIA Regional Rally Sporting Regulations, each competing car shall carry a red “SOS” sign and on the reverse a green “OK” sign measuring at least 42 cm x 29.7 cm (A3).
- In accordance with Appendix A, Article 102, of the National Sporting Code, all Competitors, teams and entrants who wish to carry on-board cameras, in-car videos and/or film cameras must have the prior agreement of the Organisers beforehand. **However, it is MANDATORY to provide the Organisers and/or the Clerk of the Course with a copy of the complete unedited recordings upon requisition with no delay.**
Authorised cameras will be identified by an adhesive decal and must be mounted in/on the car at the time of scrutineering. The mounting of on-board cameras (Interior/Exterior) to be in compliance with Appendix 7 of this Supplementary Regulations.
The On-Board Camera Application Form can be collected from the Rally Secretariat or downloaded from the ATCL official website. This form should be filled and sent to the Rally Secretariat by Monday, April 16th, 2018 at the latest.



Failing to observe this rule will be subject to a penalty at the discretion of the Stewards of the Meeting.

12 – OTHER PROCEDURES

12.1 - Ceremonial start:

Ceremonial start is not scheduled for the 34th Spring Rally.

12.2 - Official start:

The rally will start on Sunday, April 22nd, 2018 at 07:30hrs from TC 0 situated in the Casino du Liban; Maameltein.

Start area / Start holding area:

Competing cars and crews must assemble in the Start Holding Area at the Casino du Liban – Maameltein on Sunday, April 22nd, 2018 between 06:30 and 07:00hrs.

Competitors reporting late to the start area will be penalized 15- U.S. \$ per minute to a maximum of 15 minutes. Thereafter, Article 44.2 of the 2018 FIA Regional Rally Sporting Regulations will apply.

12.3 - Finish procedure:

The rally will conclude at the Finish Podium situated in the Casino du Liban – Maameltein on Sunday, April 22nd, 2018 at 17:30hrs. Competitors shall follow the Officials directions to the finish ramp, directly followed by the final Parc Fermé.

After clearing the finish ramp, the crews shall drive their cars, as instructed by the officials to the final Parc Fermé and/or scrutineering.

However, each crew may nominate a representative, duly assigned by writing, to take delivery of the car out of the final Parc Fermé. In the event that the car is not driveable this shall be reported to the Clerk of the Course and/or the Competitors' Relations Officer; the crew is solely responsible to arrange transport by a recovery vehicle at his own cost and in a timely manner.

12.4 - Early check-in at the end of a day:

Crews are authorised to check in early without incurring a penalty at:
TC 8A End of Leg 1 / Finish Podium

12.5 - Special procedures / activities:

12.5.a - Starting system:

The timekeeping in the special stages will be carried out to the 1/10th of a second.

The start of the special stages will be carried out by an electronic countdown system, placed on the left hand side of the road, between 2 and 5 meters ahead of the starting line, counting down by seconds and clearly visible to the crew from the start position.

This system is electronically coupled to a start line detection device that records any situation where a car leaves the start line ahead of the correct signal. This

system may also be synchronized with a starting lights system of which the description and regulations will be included if appropriate in a bulletin.

Should the above starting light panel fail to function; the start will be given in accordance to Article 37.3 of the 2018 FIA Regional Rally Sporting Regulations.

12.5.b - Starting order and interval:

- a) The starting order will be determined as follows:
 - FIA priority drivers
 - MERC priority drivers
 - Lebanese ASN priority drivers - Rallies
 - Other drivers
- b) All drivers will have an interval of one minute (**1min.**) between their start times.

12.5.c - Time card change during the rally:

The Time Cards will be issued at the following time controls:

Section 1	TC 0	Start Leg 1 / Section 1
Section 2	TC 2B	Regrouping OUT
Section 3	TC 5B	Regrouping OUT

When retiring, the crew are obliged to hand their time card either to the next time control or otherwise to the Sweeper car.

12.6 - Official Time:

The official time throughout the entire rally will be based on GPS time (UTC +3 hours).

A display of the “Official Time” will be located at the event headquarters as well as on the starting podium.

12.7 – Excessive speed during the rally:

In compliance with Article 20.3.4 of the 2018 FIA Regional Rally Sporting Regulations, speeding during the rally will incur a fine applied by the clerk of the course as follows:

- € 25 per km per hour over the speed limit.

The amount of this fine will be unaltered by any fine imposed by the police.

13 - IDENTIFICATION OF OFFICIALS

The post chiefs and other officials will be identified as follows:

Senior Rally Officials	White shirts with their names in dark blue letters on their left.
Competitors’ Relations Officers	Pink shirts with “C.R.O.” in large white letters weaved on their back.
Headquarters staff	Light grey shirts.
Media staff	Light yellow shirts.

Stages Commanders	Blue shirts bearing the A.T.C.L logo on it.
Stages Safety Officers	Navy blue shirts with “SAFETY” weaved on their back.
Stages Time Control Officers	Yellow tabards with "TEAM LEADER" in blue.
Special Stages posts chiefs	Yellow tabards with "TEAM LEADER" in blue.
Stages Doctors	Bright red tabards with "DOCTOR" in black.
Safety Marshals	Bright yellow tabards with "SAFETY" in grey.
Intermediary and Radio Points	Bright yellow tabards with blue radio point symbol.
Red flag marshals	Bright orange tabards with black radio point symbol.
Special Stages Marshals	Blue tabards with "MARSHALS" in white.

14 - PRIZES

14.1 - Prize-giving:

- The prize giving shall take place on the podium at the finish ramp situated in the Casino du Liban – Maameltein on Sunday, April 22nd, 2018 at 17:30hrs.
- Competitors that are not personally present at the prize giving ceremony will lose their right to the prizes that are theirs. Nevertheless, the classification and attribution of the other prizes won't be modified.

14.2 - Prizes:

List of prizes and cups:

- General Classification:

First	2 Trophies.
Second	2 Trophies.
Third	2 Trophies.
- Class RC2/N4 Cup 2 Trophies (1st crew).
- Class RC3 Cup 2 Trophies (1st crew).
- Class RC4 Cup 2 Trophies (1st crew).
- Class RC5 Cup 2 Trophies (1st crew).
- Promotion Classification: 2 Trophies (1st in Promotion Classification, as per these Supplementary Regulations, Article 4.3.4).
- Junior Drivers/Co-Drivers Cup 2 trophies, 1st junior crew in the general classification.
- Ladies Cup: 2 Trophies, 1st Female Crew.
- All finishers: 2 Medals.

The Junior Drivers/Co-Drivers Cup will be awarded to the first junior driver and co-driver in the general classification registered for the 34th Spring Rally. In

compliance with Article 12, Appendix A of the 2018 National Sporting Code to qualify for this cup, the following conditions will apply:

- The Driver/Co-Driver must have his/her 26th birthday after the end of the current year.
- The Driver/Co-Driver must be driving a 2WD cars of class RC3, RC4 and RC5.
- The driver and co-driver may not necessarily be members of the same crew.

15 - FINAL CHECKS AND PROTESTS

15.1 - Final checks:

The final scrutineering will take place at the Casino du Liban – Maameltein on Sunday, April 22nd, 2018 at 18:00hrs.

Cars subject to final checks (decision by the Stewards) must have one representative for the entrant as well as mechanics, in case of dismantling, present at the final check.

15.2 - Protest and Protest Deposits:

- a) Accompanied with the protest deposit, all protests must be lodged in writing and handed to the clerk of the course within the time set in Article 13 of the 2018 International Sporting Code.
- b) In compliance with Article 55 of the 2018 FIA Regional Rally Sporting Regulations, each protest deposit is set at € **1,000**, which shall not be returned if the protest is judged unfounded.

If the protest requires the dismantling and the re-assembly of different part of a car, the claimant must pay an additional deposit:

- i. If the protest involves a clearly defined part of the car (engine, transmission, steering, braking system, electrical installation, bodywork, etc.): **USD2,000** per each.
 - ii. Protests involving the whole vehicle are inadmissible.
- c) The expenses incurred in the work and in the transport of the vehicle shall be borne by the claimant if the protest is unfounded, or by the competitor against whom the protest is lodged if the claim is founded.
 - d) If the claim is unfounded, and if the expenses incurred by the protest (scrutineering, transport etc.) are higher than the guarantee deposit, the difference shall be borne by the claimant.

Conversely, if the expenses are less, the difference shall be returned to him.

15.3 - Appeal deposit:

- a) The sum of the National appeal deposit (ASN): **USD4,000**

APPENDIX 1: ITINERARY OF THE RALLY

34TH SPRING RALLY

LEG 1		Sunday, April 22 nd , 2018				
TC	LOCATION	SS dist.	Liaison dist.	Total dist.	Target time	First car due
0	Start – Casino du Liban	-	-	-	-	07:30
1	Nahr Ibrahim	-	11.79	11.79	00:22	07:52
SS1	NAHR IBRAHIM 1	15.42	-	-	-	07:55
2	Monsef	-	29.50	44.92	00:55	08:50
SS2	MONSEF 1	14.63	-	-	-	08:53
2A	Regrouping & Technical Zone IN	-	35.37	50.00	01:00	09:53
2B	Regrouping OUT / Service IN	-	-	-	00:13	10:06
Service A – Adma (LBCI parking)		30.05	76.66	106.71	00:30	
2C	Service OUT	-	-	-	-	10:36
RZ	Refuel – Adma (LBCI parking)	30.05	76.66	106.71		
1	Distance to next refuel	31.34	80.71	112.05		
3	Ghazir, Maameltein	-	4.07	4.07	00:15	10:51
SS3	CASINO DU LIBAN 1	1.29	-	-	-	10:54
4	Nahr Ibrahim	-	11.77	13.06	00:25	11:19
SS4	NAHR IBRAHIM 2	15.42	-	-	-	11:22
5	Monsef	-	29.50	44.92	00:55	12:17
SS5	MONSEF 2	14.63	-	-	-	12:20
5A	Regrouping & Technical Zone IN	-	35.37	50.00	01:00	13:20
5B	Regrouping OUT / Service IN	-	-	-	00:13	13:33
Service B – Adma (LBCI parking)		31.34	80.71	112.05	00:30	
5C	Service OUT	-	-	-	-	14:03
RZ	Refuel – Adma (LBCI parking)	31.34	80.71	112.05		
2	Distance to Finish	31.34	78.39	109.73		
6	Ghazir, Maameltein	-	4.07	4.07	00:15	14:18
SS6	CASINO DU LIBAN 2	1.29	-	-	-	14:21
7	Nahr Ibrahim	-	11.77	13.06	00:25	14:46
SS7	NAHR IBRAHIM 3	15.42	-	-	-	14:49
8	Monsef	-	29.50	44.92	00:55	15:44
SS8	MONSEF 3	14.63	-	-	-	15:47
8A	Finish Holding Area IN	-	33.05	47.68	01:00	16:47
Finish Podium – Casino du Liban		-	-	-	-	17:00
Finish Podium – Casino du Liban		31.34	78.39	109.73		
Sunday totals		92.73	235.76	328.49		
TOTALS OF THE RALLY						
		SS	Liaison	Total		%
	Leg1: Sections 1, 2 and 3	92.73	235.76	328.49	% of SS	28.23
	TOTAL – 8 Special Stages	92.73	235.76	328.49		28.23

Dawn: 05:33hrs
Sunrise: 05:59hrs
Sunset: 19:14hrs

APPENDIX 2:

RECONNAISSANCE SCHEDULE

ALL COMPETITORS

Start: Friday, April 22nd, 2018 at 08:00hrs

End: Friday, April 22nd, 2018 at 17:00hrs

SS 1 / 4 / 7 – Nahr Ibrahim

SS 2 / 5 / 8 - Monsef

SS 3 / 6 – Casino du Liban

- a) It is emphasized that reconnaissance is not a practice run. The competitors must drive in a manner that does not endanger or cause inconvenience to traffic or people living within and near the stages.
- b) Reconnaissance outside the aforementioned Reconnaissance Schedule, from the dates of publication of the itinerary to the Start of the Rally is **PROHIBITED**. The presence of any entrant and/or crew member entered in the rally on any part of a special stage, in any way whatsoever, is considered as reconnaissance. If any crew and/or competitor is found outside the Reconnaissance Schedule, on any part of any special stage to be used in the rally, he or she will be reported to the stewards who may apply penalties at their discretion.
- c) Crews will only be permitted to enter and leave special stages through the start and finish controls shown in the Road Book and may not under any circumstances drive in a direction opposite to that of the rally.
- d) The Reconnaissance Schedule starts at 08:00hrs and ends at 17:00hrs.
- e) **Maximum speed limit of 70 km/h** during reconnaissance is imposed on all special stages, unless another speed limit is indicated by traffic signs.
- f) All cars must have their headlights on at all times whilst travelling on the special stages.
- g) The Reconnaissance is restricted to **THREE PASSAGES ONLY**, per super stage.

Any competitor found in breach of these rules, will be reported to the stewards who may apply penalties at their discretion

APPENDIX 3:

COMPETITORS' RELATIONS OFFICER

The Competitors' Relations Officer is:



Michael Schucry

The Competitors' Relations Officer will be easily identified by his Pink shirt with "C.R.O." in white letters weaved on his right.

PRESENCE DURING THE RALLY:

When the Secretariat is opened, a planning of the places and schedule where he will be on duties will be established. This planning will be post on the Official Notice Board and will include:

- Presence at Documentation and Scrutineering
- At the Secretariat of the Meeting.
- At the Start of the Rally.
- At the Regrouping halts.
- At the Service Parks.
- Near the Parc Fermé(s) and the Finish (the latter being dependent on the rally timetable).

FUNCTION:

The principal duty of the CRO is to provide information or clarifications in connection with the regulations

MEDIATION:

- Avoid forwarding questions to the stewards which could be solved satisfactorily by a clear explanation with the exception of protests (for example, clarify disputes over times, with the assistance of the time-keepers).
- The Competitor's Relations Officer shall refrain from saying anything or taking any action which might give rise to protests.

APPENDIX 4:

IDENTIFICATION NUMBERS, ADVERTISING AND NAMES

Identification Numbers and Compulsory Advertising:

- 1 2 x Door Panel with Competition Number 67x17cm. The top of the plate shall be placed between 7 cm and 10 cm below the bottom window line. No other signage shall be placed within 10 cm of the plate. (1)

(Roof Panel (2) not applicable during the 34th Spring Rally)

- 2 Rear window panel with Competition Number 30x10cm. It shall be positioned at the top of the rear window in a central location. An adjacent area of 15x15cm containing a 14cm high Competition Number coloured in fluorescent orange (PMS 804). The number must be visible from the rear at eye level. (3)
- 3 Front rally plate 43x21.5cm. (4)
- 4 Rear side windows: (5)
2 x Competition Number 20 cm high with a stroke width of 25 mm coloured in fluorescent orange (PMS 804) shall be placed on the rear side windows adjacent to the crew's name.

The name of the driver with his/her passport nationality national flag must appear on the rear side window of both sides of the car (under the Competition Numbers). The Surname alone shall be:

- 5.1 In Helvetica upper case for the first letter of the name and the remainder in lower case
- 5.2 In white on a clear background.
- 5.3 To a height of 6cm. and a stroke width of 1.0cm.

Organisers' Optional Advertising:

- 1 A 10cm. high strip on the upper part of the windscreen, according to Article 16.7 of the 2018 International Sporting Code (6).
- 2 One space on each Front Door of the vehicle (67cm x 17cm) situated 10cms beneath the Door Panel (7).

A FURTHER BULLETIN WILL DETERMINE THE ADVERTISING BRANDS.

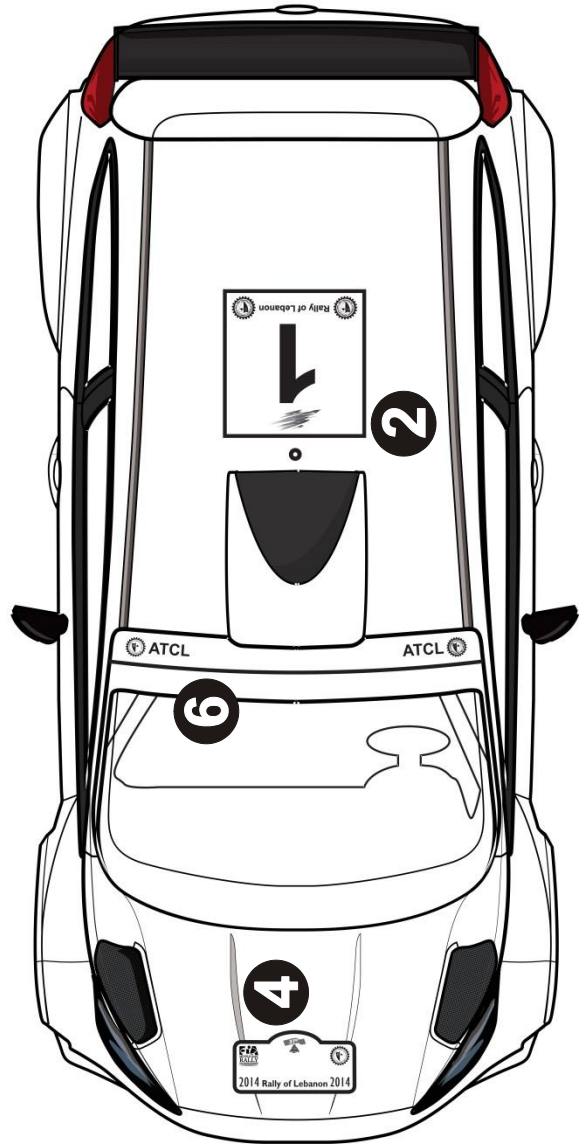
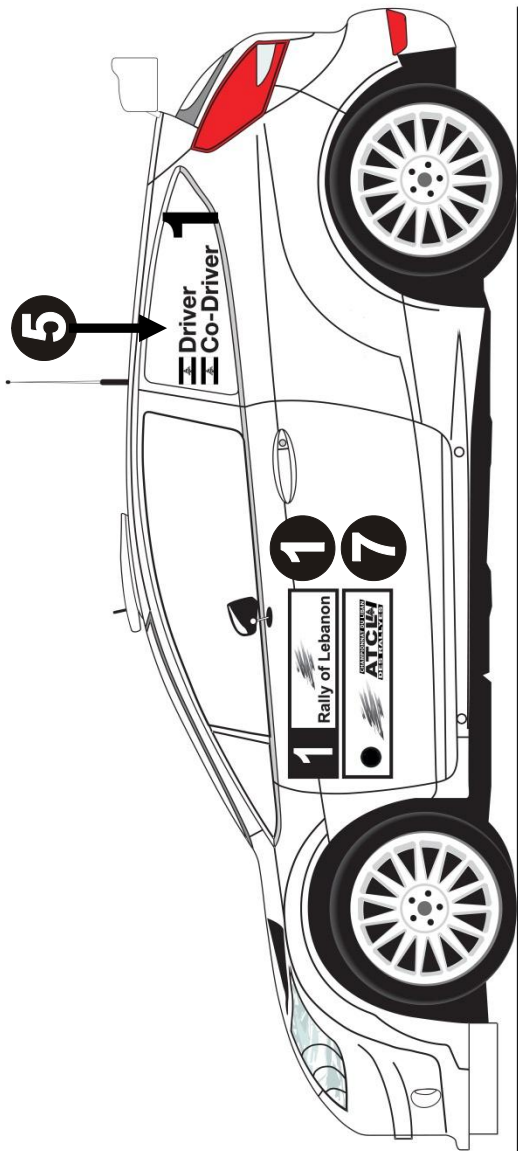
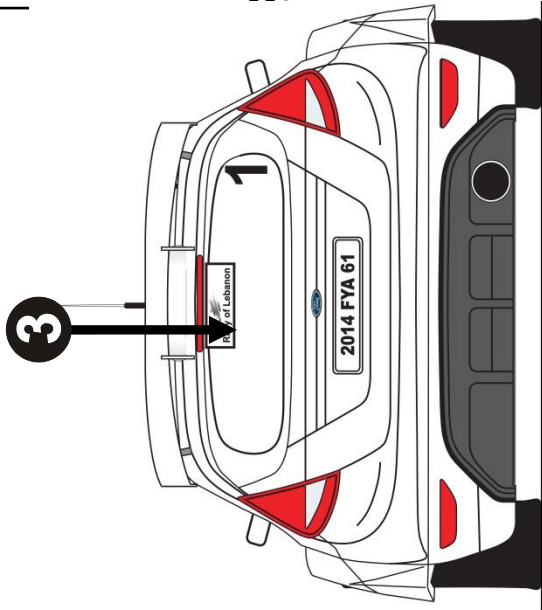

APPENDIX 5:

EXTRACTS FROM FIA APPENDIX L

1. Helmets

All drivers must wear crash helmets which meet one of the standards listed in FIA Technical List N° 25.

When the use of a Frontal Head Restraint system (FHR) is mandatory, only helmets approved in accordance with FIA standard 8858 (Technical List N°41), 8860 (Technical List N°33) or 8859 (Technical List N°49) are authorized.

2. Flame-resistant clothing

On special stages of rallies, all drivers and co-drivers must wear overalls as well as gloves (optional for co-drivers), long underwear, a balaclava, socks and shoes homologated to the FIA 8856-2000 standard (Technical List N°27).

Users must ensure that garments are not too tight, as this reduces the level of protection.

Embroidery sewn directly onto the overalls shall be stitched onto the outermost layer only, for better heat insulation. Backing material of badges and thread used for affixing them to the overalls must be flameproof.

Printing on drivers' clothing must be carried out only by the manufacturer of the product and must be flameproof and in conformity with the standard ISO 15025. It must not reduce heat transmission performance as defined in Appendix L, Article 8.2. (see Appendix 1 of the FIA 8856-2000 Standard for detailed requirements and instructions for use).

3. Frontal Head Restraint (FHR)

The wearing of any device intended to protect the head or neck and attached to the helmet is prohibited, unless the device has been homologated according to the FIA 8858 standard. Homologated FHR systems are listed in the FIA Technical List N° 29. The minimum reclined HANS collar angle shall be 60° from the horizontal.

Any padding used between the driver and the HANS® yoke must not be more than 15 mm thick when the driver is seated in the car fully equipped with the harness tightened. The padding must be covered by a flameproof material in conformity with the standard ISO 15025 and the padding must not be wider than 8 mm on each side of the HANS® yoke.

FHR systems must be worn only with FIA-approved items according to the following chart:



Helmet	Tether system (tether, tether end fitting and helmet anchorage)
FIA 8860 (Technical List N° 33)	
FIA 8858 (Technical List N° 41)	FIA 8858 (Technical List N° 29)
FIA 8859 (Technical List N° 49)	

For more details, when the device used is the HANS[®], the “Guide for the Use of HANS[®] in international motor sport”, published by the FIA Institute for Motor Sport Safety, can be found on www.fia.com, under the heading FIA Sport - Regulations - Drivers’ Equipment.

4. Safety Belts

Drivers must be properly restrained in their seat by safety belts in conformity with the specifications of Appendix J for the vehicle concerned, at all times during an event when it is mobile on a circuit, pit lane, special stage or competition course.

APPENDIX 6:

EXTRACTS FROM 2018 FIA REGIONAL RALLY SPORTING REGULATIONS

40. COMPETITOR SAFETY

40.1 EQUIPMENT OF THE CREWS

Whenever a car is in motion on any type of special stage, the crew must wear homologated crash helmets, all required safety clothing and equipment in compliance with Appendix L Chapter III - Drivers' Equipment and have their safety belts correctly fastened. Any infringement will be penalised by the Stewards.

40.2 SOS/OK SIGNS

40.2.1 Each competing car shall carry a red "SOS" sign and on the reverse a green "OK" sign measuring at least 42 cm x 29.7 cm (A3).

40.2.2 In the case of an accident where urgent medical attention is required, when possible the red "SOS" sign should be immediately displayed to the following cars and to any helicopter attempting to assist.

40.2.3 Any crew which has the red "SOS" sign displayed to them, or which sees a car which has suffered a major accident where both crew members are seen inside the car but are not displaying the red "SOS" sign, shall immediately and without exception stop to render assistance. All following cars shall also stop. The second car at the scene shall proceed to inform the next radio point. Subsequent cars shall leave a clear route for emergency vehicles. All crews stopped by this procedure will be allocated a time according to Art. 39.

40.2.4 In the case of an accident where immediate medical intervention is not required, the "OK" sign must be clearly shown to the following vehicles and to any helicopter attempting to assist.

40.2.5 If the crew leaves the vehicle, the "OK" sign must be displayed so that it is clearly visible to all following crews.

40.2.6 Any crew which is able but fails to comply with the above rules will be reported to the clerk of the course.

40.2.7 The road book shall contain a page giving the accident procedure.

40.2.8 Any crew retiring from a rally must report such final retirement to the organisers as soon as possible, save in a case of force majeure. Any crew failing to comply will be subject to a penalty at the Stewards' discretion.

40.3 ACCIDENT REPORTING

If a crew is involved in an accident in which a member of the public sustains physical injury, the driver or co-driver concerned must remain at the scene and stop the following car, which must report this to the next radio point as specified in the road book and signed on the route. The laws of the country in which the rally is run must also be complied with in relation to procedures at accidents. All crews stopped by this procedure will be allocated a time according to Art. 39.

40.4 RED TRIANGLE

40.4.1 Each competing car must carry a red reflective triangle which, in the event of the car stopping in a special stage, must be placed in a conspicuous position by a member of the crew at least 50 meters before the car's position, in



order to warn following drivers. The triangle has to be placed on the same side of the road as the car.

Any crew failing to comply may be subject to a penalty at the discretion of the Stewards.

40.4.2 This triangle must be placed even if the stopped car is off the road.

40.5 USE OF RED FLAGS

40.5.1 On passing a displayed Red Flag, the driver must immediately reduce speed, maintain this reduced speed until the end of the special stage, and follow the instructions of any marshals or intervention car drivers. Flags will be displayed at all radio points preceding the incident. Failure to comply with this rule will entail a penalty at the discretion of the Stewards.

40.5.2 A crew which has been shown the Red Flag will be allocated a time according to Art. 39.

APPENDIX 7:

MOUNTING OF ON-BOARD CAMERAS INTERIOR / EXTERIOR

1- INTERIOR MOUNT

The mounting should be of a rigid type, placed in the centre behind the back of the seats.

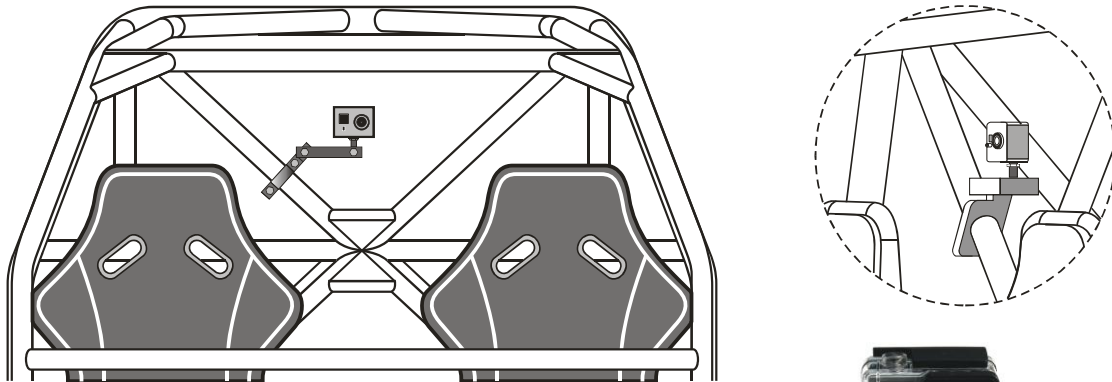

Handlebar Mount



For pencil type cameras, they can be mounted on the front rollbar windscreen pillar, the control unit should be fixed on the floor pan behind the seats. (Similar to battery fixation)

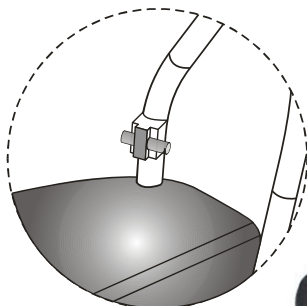

On front Rollbar

OR

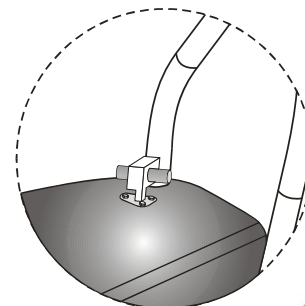

On dashboard



2- EXTERIOR MOUNT

A support bracket of 40mm. fixed by screws with a reinforcement plate of minimum 3mm thick and a surface of 120 cm² should be used

IMPORTANT: The reinforcement plate should be placed from inside the body work in order to reinforce the support area.

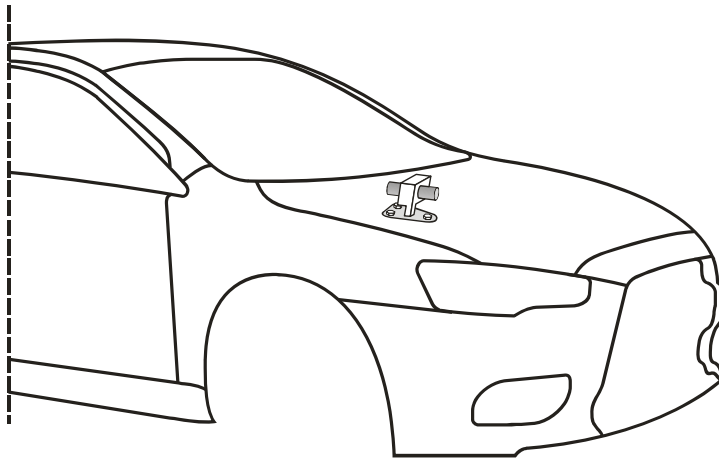

3- PROHIBITED MOUNTINGS

